

Unical[®]

TRIOPREX N

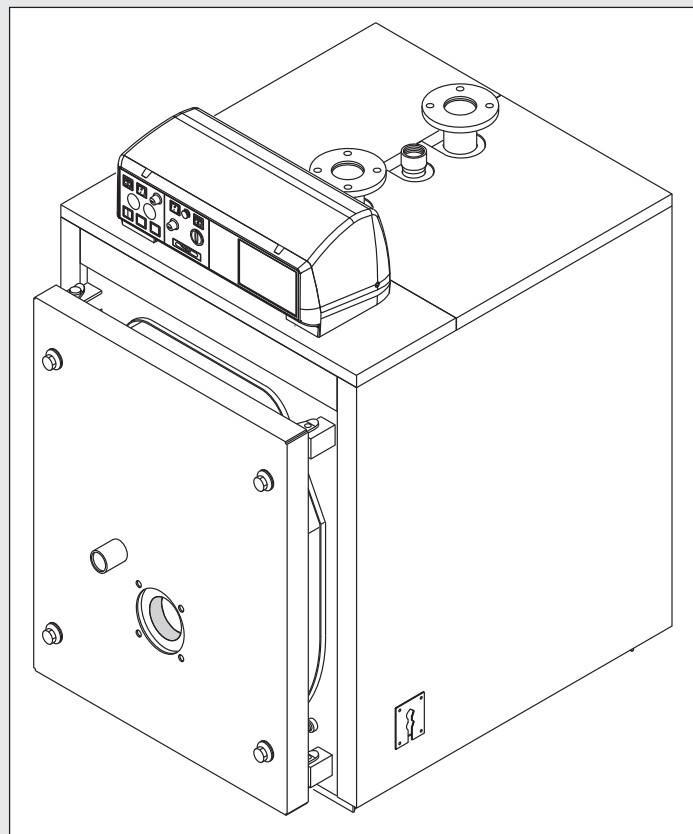

**INSTALLATION, USE AND
SERVICING INSTRUCTION**
(to be kept by the user)

WARNING

When the boiler is operated with a pressure jet gas burner, because it does not belong to any of the categories among those listed in the Annex II to the Directive 97/23/CE (regarding pressure equipment) and being, furthermore, mentioned in the Directive 90/396/CE (Gas Appliance Directive) to which the art. 1, clause 3, paragraph 6.5 makes reference, it is excluded from the scope of the Directive.

GENERAL INFORMATIONS

Introduction

This manual supplies a summary of what has to be followed during the installation, use and servicing of the UNICAL boilers, TRIOPREX-N range.

In the course of this text the short name TX-N can be used to indicate the TRIOPREX-N boiler.

Choice of the boiler

For a correct choice and application of the TX-N boilers it is necessary to follow the instructions given in this manual.

Installation

The installation of the boilers and the auxiliary equipments, related to the heating system, must be in conformity with all the regulations and rules in force.

It is law that all the gas appliances are installed, commissioned and serviced by a registered installer in accordance with the regulations below. Failure to install appliances correctly could lead prosecution. It is in your own interest, and that of the safety, to ensure the law is complied with.

The following must be complied with:

Current Building Regulations and Clean Air Act.

Water Authority Regulations.

Local Authority Regulations and Regional Bylaws.

Gas Safety Regulations.

Any special regional requirements of local Electricity and Gas undertaking.

Fire Service and Insurance Company requirements.

Commissioning

The main purpose of the commissioning is to verify the correct operation of all the safety and control devices.

Before leaving the installation the commissioner has to control the operation of the boiler for, at least, a complete working cycle.

Guarantee

The boiler guarantee is bound to the compliance of the the requirements stated in this manual, and any non-fulfilment or modification will make it void.

Normative

It is the responsibility of the installer to fulfil all the regulations concerning the boiler house, the safety devices, the chimney, the fuel supply lines, the electrical installations and all the other local requirements and safety instructions.

Approvals

The UNICAL boilers, TRIOPREX-N range, have been tested and CE certified for the gas operation by TECHNIGAS (BELGIUM), who has recognised to these boilers the conformity certificate according to the following directives:

- Gas Appliances Directive (90/396 CE), compulsory as per 1st January 1996;
- Efficiency Directive (92/42 CE), compulsory as per 1st January 1998;
- The conformity to the Low Voltage Directive (73/23 CE), compulsory as per 1st January 1997 has been verified and ascertained by GASTEC ITALIA.

The conformity to the EMC (Electro Magnetic Compatibility 89/336 CE), compulsory as per 1st January 1996, is not applicable to the TRIOPREX-N boilers because they do not have electronic components.

For the time being there are no European Directives covering the oil fired boilers, except the Efficiency Directive (92/42 CE).

Data plate and Serial No.

The data plate, supplied in a separate envelope with the relevant documents, makes reference to a serial No, embossed in an aluminium plate riveted to the front tube plate in the lower RH side corner.

Use of the boiler

This boiler has to be used for heating the water at a temperature not higher than the boiling temperature in the installation conditions.

GAS SAFETY (INSTALLATION AND USE) REGULATIONS, 1994

It is law that **all** gas appliances are installed and serviced by a CORGI registered installer in accordance with the above regulations. Failure to install appliances correctly could lead to prosecution.

It is in your own interest, and that of safety, to ensure the law is complied with.

The installation of the boiler **MUST** also be in accordance with the latest I.E.E. Wiring Regulations, local building regulations, byelaws of the local water authority, the building regulations and the Building Standards

(Scotland) and any relevant requirements of the local authority.

Detailed recommendations are contained in the following British Standard Codes of Practice:

- | | |
|---------|--|
| BS 6891 | Low pressure installation pipes. |
| BS 5449 | Forced circulation hot water systems. |
| BS 5546 | Installation of gas hot water supplies for domestic purposes (2nd Family Gases). |
| BS 6644 | Ventilation (for gas appliances of rated input exceeding 60 kW). |

HEALTH & SAFETY DOCUMENT No. 635

The Electricity at Work Regulations, 1989.

The manufacturer's notes must **NOT** be taken, in any way, as overriding statutory obligations.

IMPORTANT. These appliances are CE certificated for safety and performance. It is, therefore, important that no external control devices, e.g. flue dampers, economisers etc., are directly connected to these appliances unless covered by these Installation and Servicing Instructions or as otherwise recommended by **Unical** in writing. If in doubt please inquire.

Any direct connection of a control device not approved by **Unical** could invalidate the certification and the normal appliance warranty.

Notes.

To obtain the gas consumption:

- For l/s divide the gross heat input (kW) by C.V. of the gas (MJ/m³).
- For ft³/h divide the gross heat input (Btu/h) by C.V. of the gas (Btu/ft³).

1

CONSTRUCTIONAL-DIMENSIONAL TECHNICAL CHARACTERISTICS	page	5
1.1 Construction of the TRIOPREX-N boilers	page	5
1.2 Working principle	page	5
1.3 Dimensions and hydraulic connections	page	6

2

INSTALLATION	page	11
2.1 Packaging	page	11
2.2 Handling	page	11
2.3 Positioning in the boiler house	page	11
2.4 Connection to the chimney	page	12
2.5 Water connections	page	12
2.5.1 Feeding water quality	page	12
2.5.2 C.H. flow and return connections	page	12
2.5.3 Connection of filling & drain tap	page	12
2.5.4 Connection of the pressure relief valve	page	12
2.5.5 Connection of the expansion pipe and vessel	page	12
2.5.6 Shunt pump	page	13
2.6 Furnace door: adjustment, opening and closing	page	13
2.6.1 Important note	page	13
2.7 Burner	page	13
2.7.1 Conformity of the burner	page	13
2.7.2 Choice of the burner	page	13
2.7.3 Burner installation	page	13
2.8 Connection of the sightglass to the burner via a cooling line ..	page	14
2.9 Casing assembly	page	15

3

STANDARD PANEL BOARD	page	24
3.1 Panel board type 21056/21057 - functions description	page	24
3.2 Electrical wiring diagram for single phase burner & pump ..	page	24
3.3 Introduction of the electronic panel board type 30688	page	25
3.4 Panel board type 30688 - description of functions	page	25
3.5 Electrical wiring diagram for single phase burner & pump ..	page	26
3.6 Outer compensator	page	27
3.7 Electrical and hydraulic connections of C.H.	page	32
3.8 Electrical and hydraulic connections for C.H. system and D.H.W. production circuits	page	32

4

COMMISSIONING AND OPERATION	page	33
4.1 Positioning of the turbulators	page	33
4.2 Preliminary check	page	34
4.3 First commissioning	page	34
4.4 Operation of the boiler	page	34
4.5 Switch Off of the boiler	page	34

5

MAINTENANCE	page	35
5.1 General rules	page	35
5.2 Ordinary maintenance	page	35
5.3 Extraordinary maintenance	page	35
5.4 Cleaning of the boiler	page	36
5.5 Check of the boiler operation	page	36
5.6 Check of the burner operation	page	36
5.7 Boiler house	page	36

1

CONSTRUCTIONAL-DIMENSIONAL TECHNICAL CHARACTERISTICS

1.1 - CONSTRUCTION OF THE TRIOPREX-N BOILERS

The TRIOPREX-N, three pass boilers, are of horizontal type (oval shape from model 65 to 380 and the model 840; *eight* shape from model 500 to 730 and cylindrical shape from model 1100 to 1900), with direct flame in the combustion chamber.

The construction completely satisfies the requirements of the EN 303- part 1.

The sheet metal parts of the pressure vessel are manufactured of certified carbon steel, type S235JRG2, according to EN 10025, with melting certificate 3.1.B, according EN 10024; whereas the pipes are of steel ST 37.0 according to DIN 1626.

The welders and the WPS (Welding Procedures Specifications) have been approved according to EN 287 and EN 288 by TUEV (DE). These boilers have been also approved by - ISCIR (RO).

Up to the model TX-N 380 the furnace is linked to the rear tube plate.

For larger models (TX-N 500 to TX-N 3500) the furnace is free to dilate (it is supported only by the double welding seam (inner and outer) to the front tube plate).

The boilers are equipped with a reversible hinged door, which can be opened, for this reason, from L.H. or R.H. side.

The outer shell is insulated with a glass wool mattress, thick 100 mm (80 mm for models TX-N65 & TX-N 85), protected by a textile in mineral fiber.

The upper part of the outer shell is equipped with uplift hook(s).

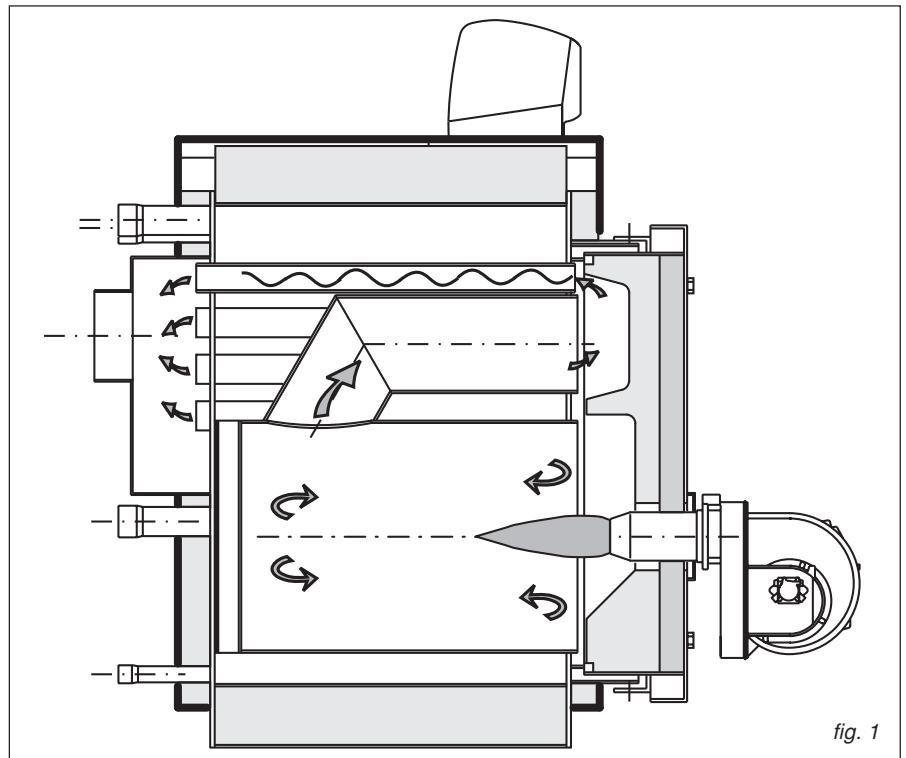

Note: The TRIOPREX-N boilers are to be equipped with ON/OFF burner; alternatively they can be equipped with a two stage or modulating burner, provided the minimum reachable heat input is not lower than the figure shown on the data plate for the fuel used on site.

For two stage or modulating burner see paragraph 2.7.1.

The boilers are provided with two 1/2" bulb holders with inner diameter of 15 mm (for 3 bulbs each), suitable to locate the thermostats and thermometer bulbs.

The casing side panels are provided with holes for the cables of the electrical supply, of the pumps, of the burner and any other auxiliary equipment.

1.2 - WORKING PRINCIPLE

The NO_x formation process is strongly affected by:

- the flame temperature;
- the time during which the combustion gases stay in a high temperature zone.
- oxygen partial pressure and its concentration.

The provisions to be adopted for the NO_x reduction are then:

- reduction of combustion temperature;
- reduction of the specific thermal input;
- permanence time reduction of the gases in the combustion chamber;
- reduction of oxygen concentration.

UNICAL, to reduce the NO_x formation on the TRIOPREX-N range of boilers, has adopted the following construction solutions:

- **three pass**
the furnace is of direct flame type and not of reversal type any more; the burner flame results more compact and shorter, thus

reducing the permanence time at high temperature;

the direct pass allows a quicker flame cooling down by the water cooled furnace surfaces;

- **specific thermal input reduction**
the combustion chamber volume has been increased if compared with standard boilers of the same capacity.

With the adoption of the modern Low NO_x burners a further reduction of the NO_x emissions can be obtained with:

- **reburning**
a part of the combustion gases is taken and sent again to the combustion chamber with the combustion air.
In this way the partial oxygen pressure is reduced and the flame temperature is reduced too.
- **reduction of the partial oxygen pressure thanks to an air excess reduction**

During the operation of the burner within the output range of the boiler, the combustion chamber is always under positive pressure. For the value of this pressure see tables on pages 6 to 10 under the column "Smoke side pressure losses".

The chimney has to be calculated in such a way that at its base there is no positive pressure.

1.3 - DIMENSIONS AND HYDRAULIC CONNECTIONS FOR TRIOPREX-N

TRIOPREX-N 65÷85

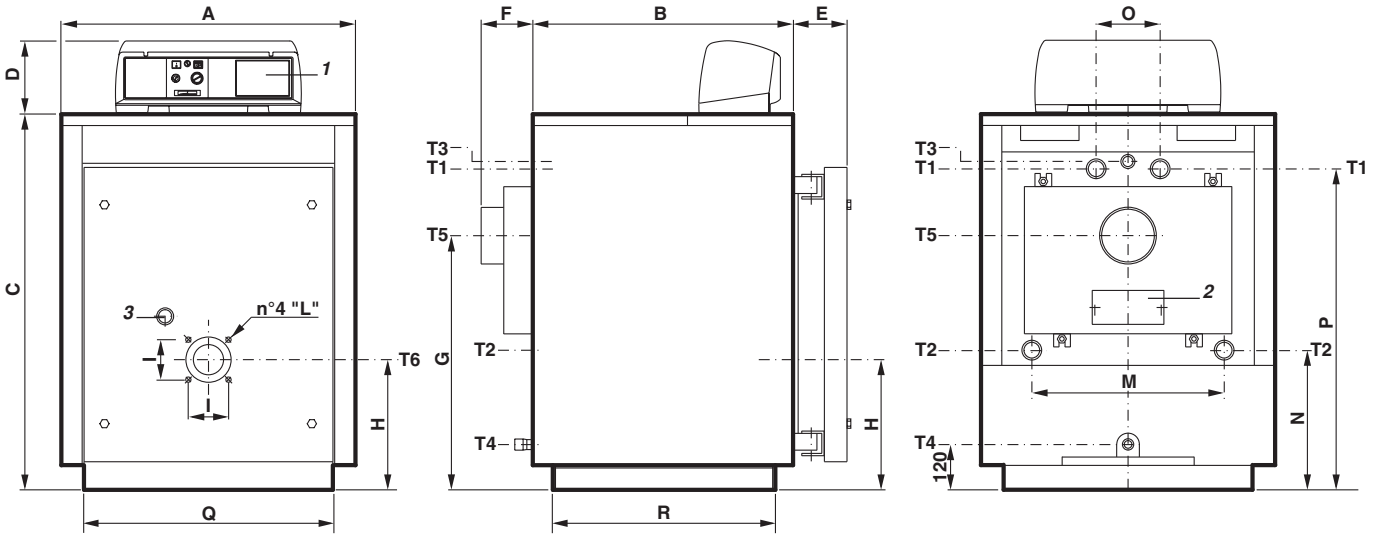

fig. 2

- 1 Panel board
- 2 Smoke chamber cleaning door
- 3 Flame sight glass

- T1 C.H. flow
- T2 C.H. return
- T3 Expansion vessel connection

- T4 Boiler drain
- T5 Flue connection
- T6 Max. burner blast tube dia.

TRIOPREX N	Output min/max	Input min/max	Boiler water content	Water side pressure drop (*)	Smoke side pressure drop	Maximum boiler working pressure	Weight with packaging	CONNECTIONS				
								T1 T2	T3	T4	T5 Ø	T6 Ø
Type	kW	kW	l	m w.c.	mm w.c.	bar	kg	ISO 7/1	ISO 7/1	ISO 7/1	mm	mm
TX N 65	55÷65	59,8÷71	131	0,04±0,06	3÷4	5	307	Rp 1½	Rp 1	Rp ¾	150	132
TX N 85	72÷85	78,3÷93	187	0,05±0,07	4,5÷6	5	348	Rp 1½	Rp 1	Rp ¾	150	132

TRIOPREX N	DIMENSIONS															
	A	B	C	D	E	F	G	H	I	L	M	N	O	P	Q	R
Type	mm	mm	mm	mm	mm	mm	mm	mm	mm	mm	mm	mm	mm	mm	mm	mm
TX N 65	740	690	950	190	140	145	660	345	120	M 8	470	310	190	846	660	590
TX N 85	740	950	950	190	140	145	660	345	120	M 8	470	310	190	846	660	850

(*) Hydraulic resistance for delta T 15K.

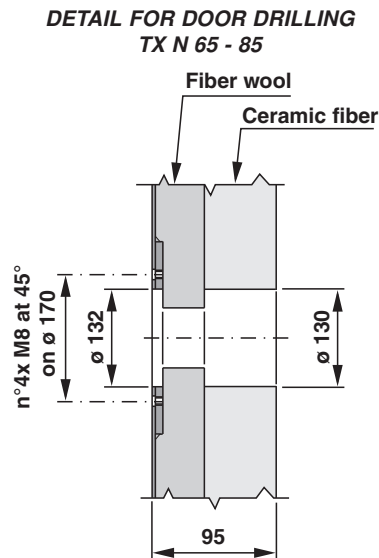

fig. 3

TRIOPREX-N 110÷380

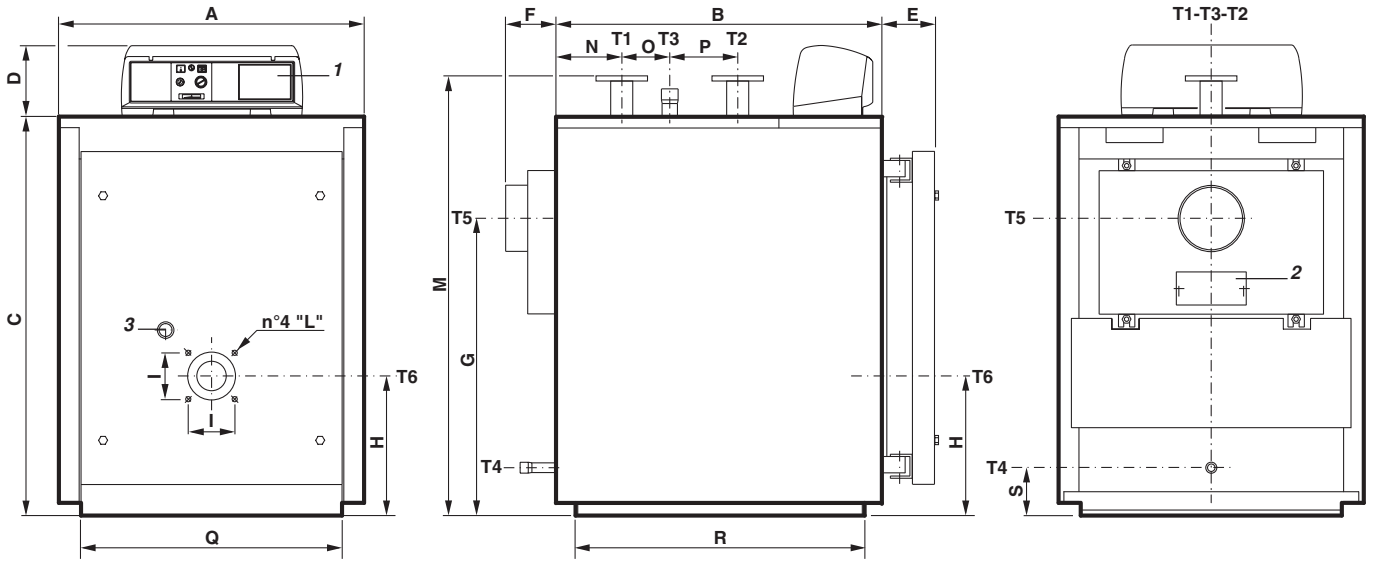

fig. 4

- 1 Panel board
- 2 Smoke chamber cleaning door
- 3 Flame sight glass

- T1 C.H. flow
- T2 C.H. return
- T3 Expansion vessel connection

- T4 Boiler drain
- T5 Flue connection
- T6 Max. burner blast tube dia.

TRIOPREX N	Output min/max	Input min/max	Boiler water content	Water side pressure drop (*)	Smoke side pressure drop	Maximum boiler working pressure	Weight with packaging	CONNECTIONS				
								T1 T2	T3	T4	T5 Ø	T6 Ø
Type	kW	kW	l	m w.c.	mm w.c.	bar	kg	UNI 2278 PN 16	ISO 7/1	ISO 7/1	mm	mm
TX N 110	93÷110	101÷120	204	0,06÷0,08	5,5÷7,5	5	426	DN 50	Rp 1¼	Rp ¾	180	132
TX N 150	127÷150	137,7÷163	270	0,08÷0,10	12÷16	5	503	DN 50	Rp 1¼	Rp ¾	180	132
TX N 185	157÷185	170÷202	285	0,10÷0,18	9÷12	5	564	DN 65	Rp 1½	Rp ¾	180	180
TX N 225	191÷225	207÷245	322	0,17÷0,20	12,5÷17,5	5	621	DN 65	Rp 1½	Rp ¾	180	180
TX N 300	255÷300	276÷327	408	0,22÷0,35	9÷12	5	812	DN 80	Rp 2	Rp ¾	225	180
TX N 380	323÷380	350÷414	475	0,32÷0,53	15÷21	5	906	DN 80	Rp 2	Rp ¾	225	180

TRIOPREX N	DIMENSIONS															
	A	B	C	D	E	F	G	H	I	L	M	N	O	P	Q	R
Type	mm	mm	mm	mm	mm	mm	mm	mm	mm	mm	mm	mm	mm	mm	mm	mm
TX N 110	820	885	1082	190	140	145	748	380	120	M 8	1210	175	130	185	710	786
TX N 150	820	1145	1082	190	140	145	748	380	120	M 8	1210	175	390	185	710	1046
TX N 185	860	1080	1182	190	140	145	828	400	--	--	1310	215	210	250	750	981
TX N 225	860	1210	1182	190	140	145	828	400	--	--	1310	215	340	250	750	1111
TX N 300	890	1275	1352	190	140	145	928	440	--	--	1485	255	285	315	780	1177
TX N 380	890	1470	1352	190	140	145	928	440	--	--	1485	255	480	315	780	1372

(*) Hydraulic resistance for delta T 15K.

DETAIL FOR DOOR DRILLING
TX N 110 - 150

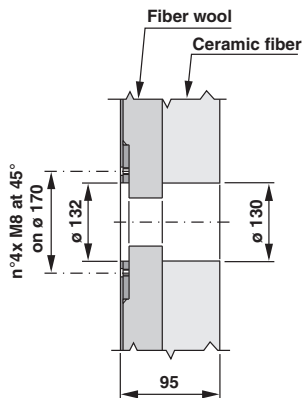

fig. 5

DETAIL FOR DOOR DRILLING
TX N 185 - 225

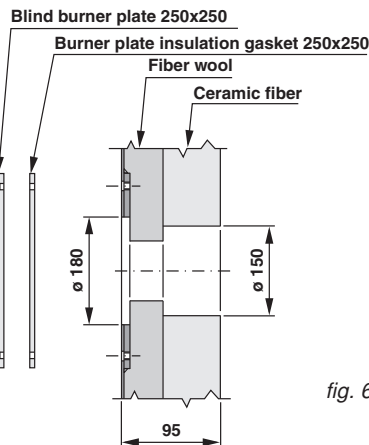

fig. 6

DETAIL FOR DOOR DRILLING
TX N 300 - 380

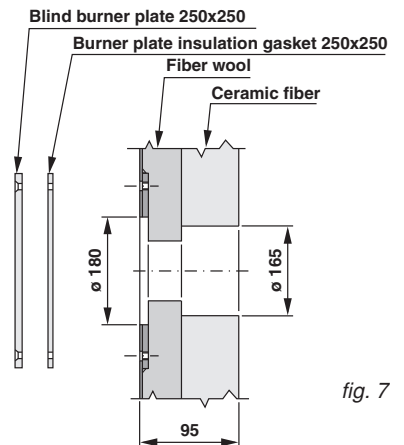

fig. 7

TRIOPREX-N 500÷730

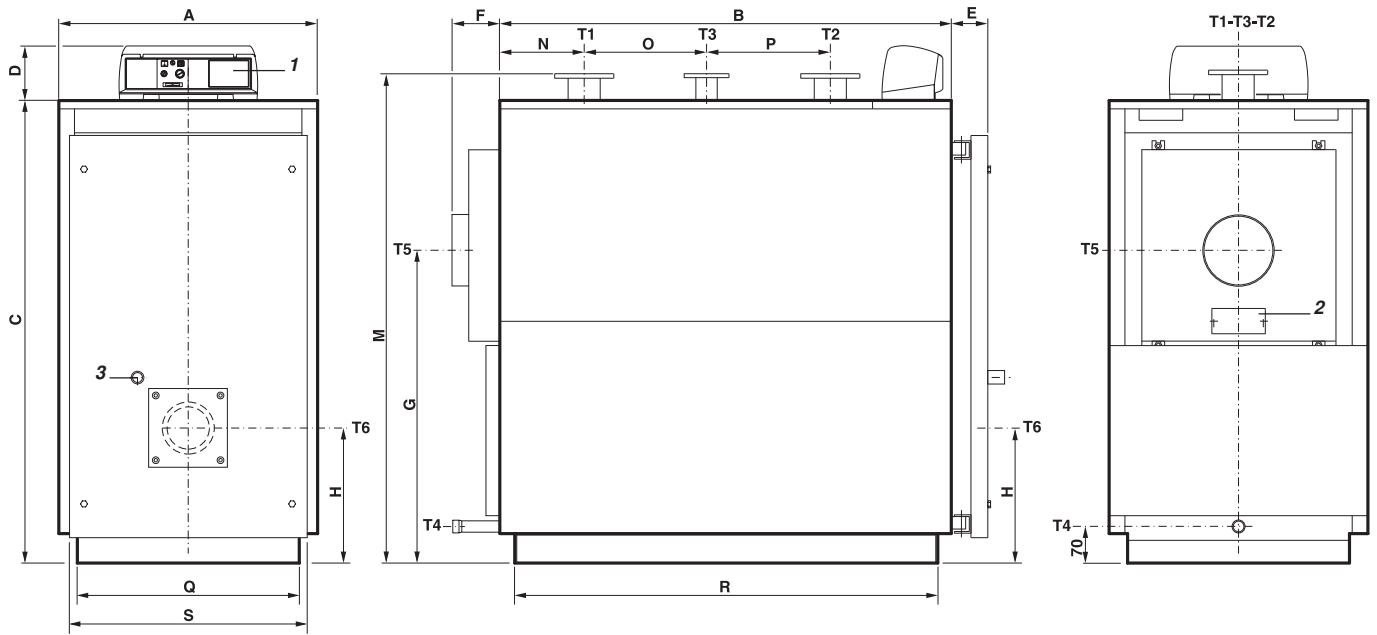

fig. 8

- 1 Panel board
- 2 Smoke chamber cleaning door
- 3 Flame sight glass

- T1 C.H. flow
- T2 C.H. return
- T3 Expansion vessel connection

- T4 Boiler drain
- T5 Flue connection
- T6 Max. burner blast tube dia.

TRIOPREX N	Output min/max	Input min/max	Boiler water content	Water side pressure drop (*)	Smoke side pressure drop	Maximum boiler working pressure	Weight with packaging	CONNECTIONS				
								T1	T2	T3	T4	T5
Type	kW	kW	l	m w.c.	mm w.c.	bar	kg	UNI 2278 PN 16	UNI 2278 PN 16	ISO 7/1	Øi mm	Ø mm
TX N 500	425÷500	460÷545	656	0,10÷0,15	25÷35	5	1198	DN 100	DN 65	Rp 1	250	220
TX N 630	535÷630	579÷686	737	0,16÷0,23	32÷45	5	1304	DN 100	DN 65	Rp 1	250	220
TX N 730	620÷730	671÷795	807	0,23÷0,33	35÷49	5	1431	DN 100	DN 65	Rp 1	250	220

TRIOPREX N	DIMENSIONS														
	A	B	C	D	E	F	G	H	M	N	O	P	Q	R	S
Type	mm	mm	mm	mm	mm	mm	mm	mm	mm	mm	mm	mm	mm	mm	mm
TX N 500	920	1605	1645	190	135	195	1110	480	1735	298	435	440	790	1505	860
TX N 630	920	1800	1645	190	135	195	1110	480	1735	298	630	440	790	1790	860
TX N 730	920	1995	1645	190	135	195	1110	480	1735	298	825	440	790	1895	860

(*) Hydraulic resistance for delta T 15K.

**DETAIL FOR DOOR DRILLING
TX N 500 - 730**

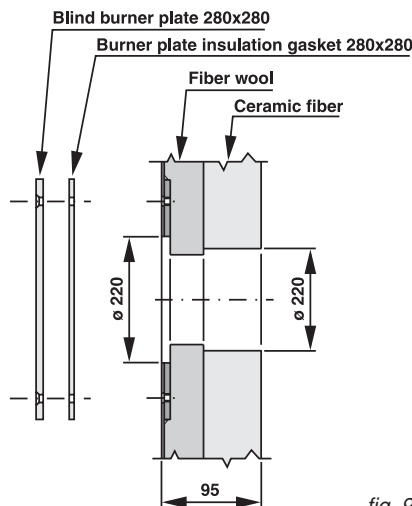

fig. 9

TRIOPREX-N 840

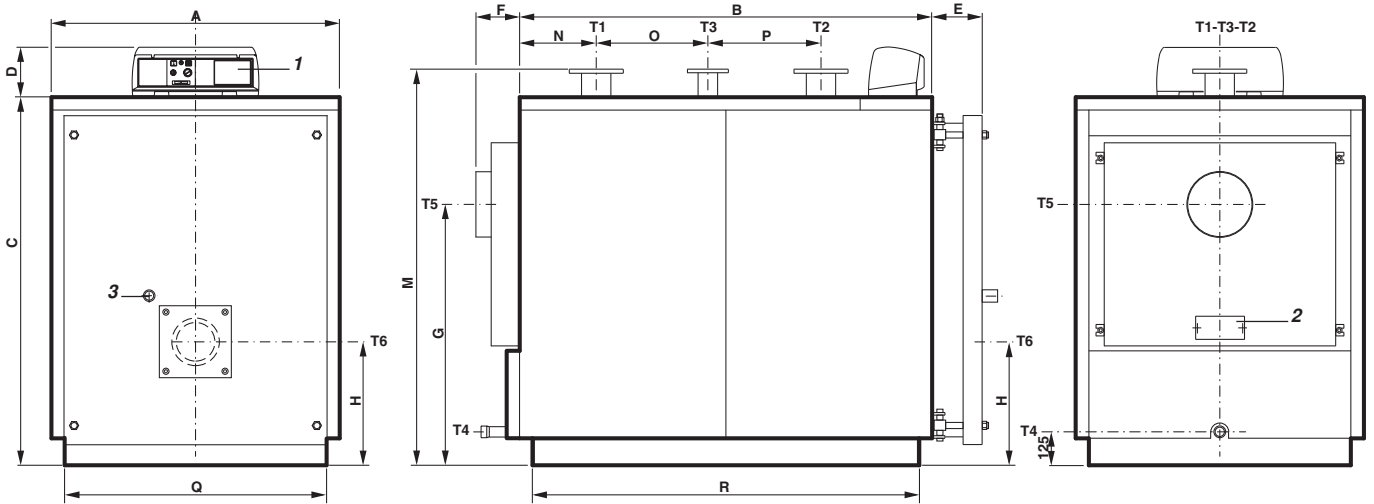

fig. 10

- 1 Panel board
- 2 Smoke chamber cleaning door
- 3 Flame sight glass

- T1 C.H. flow
- T2 C.H. return
- T3 Expansion vessel connection

- T4 Boiler drain
- T5 Flue connection
- T6 Max. burner blast tube dia.

TRIOPREX N	Output min/max	Input min/max	Boiler water content	Water side pressure drop (*)	Smoke side pressure drop	Maximum boiler working pressure	Weight with packaging	CONNECTIONS				
Type	kW	kW	l	m w.c.	mm w.c.	bar	kg	T1 T2	T3	T4	T5 Øi	T6 Ø
TX N 840	714÷840	772÷915	932	0,35÷0,52	42÷58	5	1581	UNI 2278 PN 16 DN 100	UNI 2278 PN 16 DN 65	ISO 7/1 Rp 1/4	250	270

TRIOPREX N	DIMENSIONS													
Type	A	B	C	D	E	F	G	H	M	N	O	P	Q	R
	mm	mm	mm	mm	mm	mm	mm	mm	mm	mm	mm	mm	mm	mm
TX N 840	1122	2115	1432	190	195	195	1025	480	1540	298	945	440	1020	2014

(*) Hydraulic resistance for delta T 15K.

**DETAIL FOR DOOR DRILLING
TX N 840**

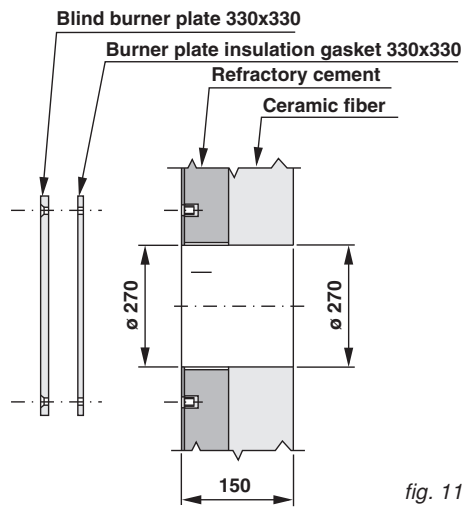

fig. 11

TRIOPREX-N 1100-1900

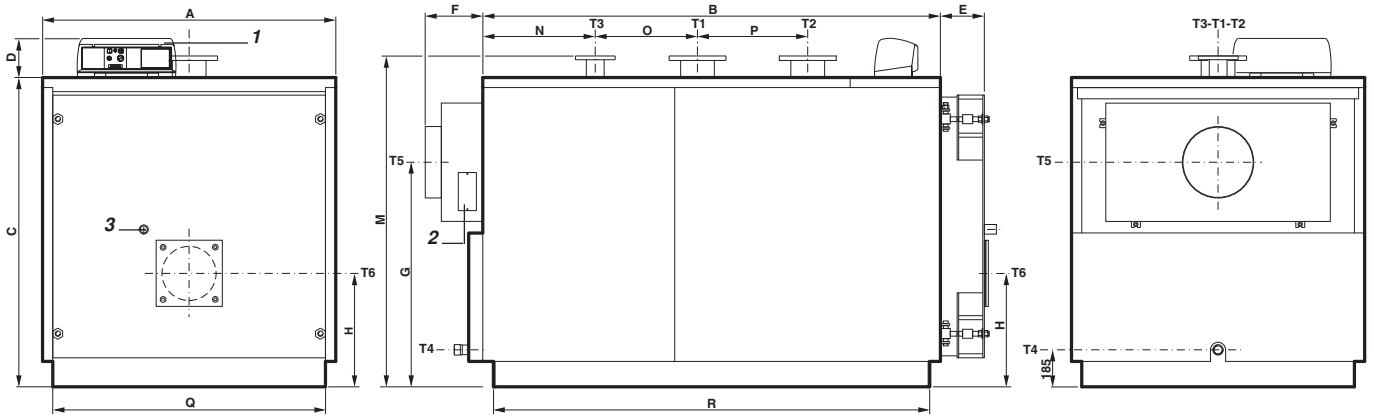

fig. 12

- 1 Panel board
- 2 Smoke chamber cleaning door
- 3 Flame sight glass

- T1 C.H. flow
- T2 C.H. return
- T3 Expansion vessel connection

- T4 Boiler drain
- T5 Flue connection
- T6 Max. burner blast tube dia.

TRIOPREX N	Output min/max	Input min/max	Boiler water content	Water side pressure drop (*)	Smoke side pressure drop	Maximum boiler working pressure	Weight with packaging	CONNECTIONS				
								T1 T2	T3	T4	T5 Øi	T6 Ø
Type	kW	kW	l	m w.c.	m m w.c.	bar	kg	UNI 2278 PN 16	UNI 2278 PN 16	ISO 7/1	mm	mm
TX N 1100	935÷1100	1012÷1198	1580	0,15÷0,21	45÷62	6	2444	DN 150	DN 80	Rp 1½	350	270
TX N 1320	1122÷1320	1214÷1438	1791	0,21÷0,30	61÷85	6	2965	DN 150	DN 80	Rp 1½	350	270
TX N 1600	1360÷1600	1470÷1743	2297	0,20÷0,28	40÷55	6	3685	DN 175	DN 100	Rp 1½	400	285
TX N 1900	1615÷1900	1745÷2070	2496	0,27÷0,39	52÷73	6	4089	DN 175	DN 100	Rp 1½	400	285

TRIOPREX N	DIMENSIONS													
	A	B	C	D	E	F	G	H	M	N	O	P	Q	R
Type	mm	mm	mm	mm	mm	mm	mm	mm	mm	mm	mm	mm	mm	mm
TX N 1100	1462	2282	1542	190	230	290	1120	565	1650	561	510	550	1360	2176
TX N 1320	1462	2652	1542	190	230	290	1120	565	1650	561	880	550	1360	2546
TX N 1600	1622	2692	1702	190	260	290	1245	605	1810	661	670	700	1520	2590
TX N 1900	1622	3014	1702	190	260	290	1245	605	1810	662	990	700	1520	2910

(*) Hydraulic resistance for delta T 15K.

DETAIL FOR DOOR DRILLING
TX N 1100 - 1320

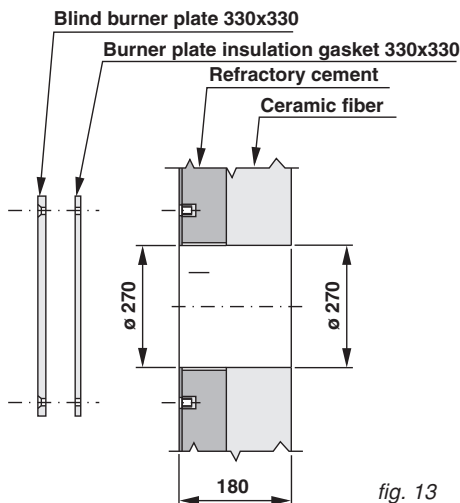

fig. 13

DETAIL FOR DOOR DRILLING
TX N 1600 - 1900

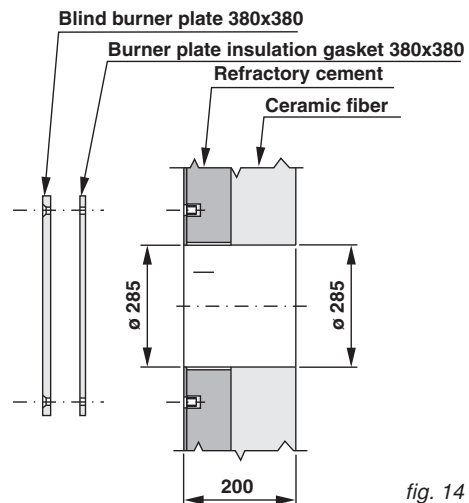

fig. 14

2

INSTALLATION

2.1 - PACKAGING

The TRIOPREX-N boilers are supplied complete with door and smoke chamber already fitted, whilst the casing with the insulation mattress are contained in separate cardboard packaging(s).

The panel board and the accessories are inside the combustion chamber. Before starting the installation make sure that

the length and the width of the boiler body received correspond to the dimensions **M**, **Q** e **R** of the ordered boiler, shown in the previous tables and that the cartons, containing the casing, or part of it, are marked with the code(s) shown on pages 14 & 15.

In addition to the a. m. panel board, packaged in its own carton, in the combustion chamber, as accessories, there are also:

- a carton containing the flanges for flow, return and safety connections (if applicable) with relevant gaskets and bolts, the cylindrical brush for the cleaning of the smoke pipes.
- cleaning brush handle extension.
- turbulators extractor.
- ceramic fiber rope for the insulation between the door and burner blast tube.

2.2 - HANDLING

The boiler can be moved into position by lifting, through the upper hooks(s), or by the use of rollers placed under the strong L

profiles of the basement. If it necessary, due to the dimensions of the boiler, it is possible to remove the front door

and the smoke chamber to facilitate the introduction in the boiler house.

2.3 - POSITIONING IN THE BOILER HOUSE

The installation of the boiler must be in accordance with the relevant requirements of the Gas Safety Regulations, current I.E.E. Regulations, local water authority bye-laws and it should also comply with any relevant requirements of the local gas supplier, local authority and the relevant Standard Codes of Practice and building regulations.

The boiler house must be ventilated through permanent openings having a total surface not lower than 1/30th of the floor area of the boiler house, with a minimum of 0.5 m².

Ventilation by grilles communicating directly with the outside air is required at both, high and low levels.

The boiler must be positioned so that there is enough space available for the following:

- Access around the boiler fore servicing.
- Space to open the boiler front door.
- Space to access the burner.

The installation of the boiler as close as possible to the chimney position is highly recommended.

To allow the cleaning of the smoke pipes, in front of the boiler a clearance equal to the length of the boiler, has to be available.

With the boiler door opened at 90°, the distance between the front of the door and the adjacent wall must be equal, at least, at the length of the burner.

The boiler must stand on a non-combustible floor (i.e. concrete or brick), of dimensions **Q** x **R** (see dimensions table) which must be flat, level and of a suitable load bearing capacity to support the weight of the boiler (when filled with water) and any ancillary equipment.

Once the installation has been made the boiler must result perfectly horizontal and well stable (to avoid vibrations and noise).

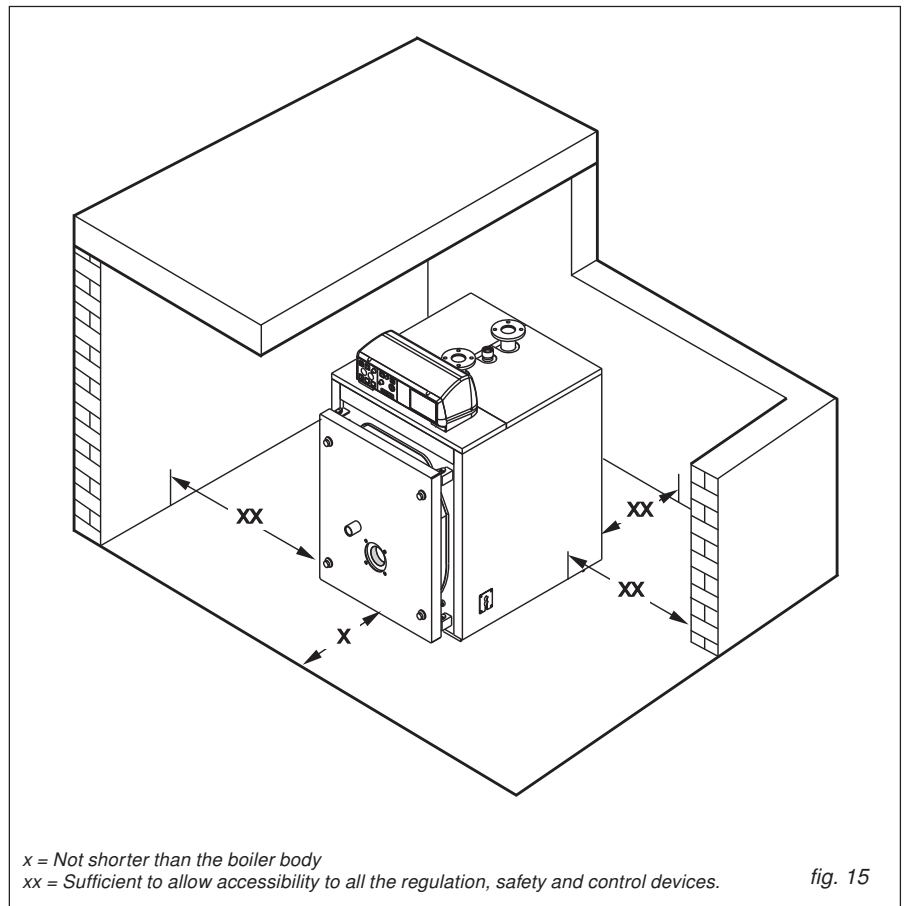

2.4 - CONNECTION TO THE CHIMNEY

The chimney has a fundamental importance for the good operation of the boiler. Due to the low temperature of the smokes during the intermittent operation, it is necessary that the chimney is perfectly impermeable to the condensate of the combustion products and manufactured with corrosion resistant

materials. The different connections must be sealed with an approved boiler putty so that the inlet of fresh air, with consequent increase of the possibility of condensate formation, is avoided. Furthermore the possible condensate or rain water coming from the chimney must be avoided from entering the smoke chamber of the boiler. As far as the cross section and the high of

the chimney is concerned, it is necessary to make reference to the local and national rules in force.

In the flue pipe, between the boiler and the chimney, convenient sampling points for smoke temperature and combustion products analysis must be provided.

2.5 - WATER CONNECTIONS

2.5.1 - FEEDING WATER QUALITY

- The chemical-physical characteristics of the C.H. system and reinstatement water are fundamental for the good operation and safety of the boiler.
- Among the inconvenients caused by the bad quality of the feeding water the most frequent and serious is the scaling of the heat exchange surfaces.
- Less frequent, but also dangerous, is the corrosion of the water side surfaces of all the circuit.

- It is well known that the lime, due to its very low thermal conductivity, reduces the heat transfer so that also a scaling of a few millimeters produces very dangerous localized overheating. 1 mm of lime reduces the heat transfer from metal to water by 10%. It is suggested to make a water treatment in the following cases:
 - A- high hardness of the water available on site (higher than 20°f).
 - B- very large C.H. systems.
 - C- large quantities of reinstatement water due to water leaks.
 - D- subsequent fillings of the system due to maintenance works.

E- mixing of different metals in the CH circuit.

For the treatment of filling water it is suggested to address them self to specialized firms. The same firms are able to provide for the descaling of the boilers. Every C.H. system needs reinstatements of water, due to evaporation, small or large water leaks or for maintenance works. It is, therefore, necessary to be able to evaluate the entity of the reinstatement water to avoid inconvenients due to untreated water. For that reason it is suggested to fit, in the feeding line to the boiler, a water meter for small capacities.

2.5.2 - C.H. FLOW AND RETURN CONNECTIONS

The dimensions of flow and return connections are shown, for each boiler model, in the table DIMENSIONS. Before connecting the boiler to the C.H. system,

this one has to be thoroughly cleaned. Make sure in the system there is a sufficient number of air venter. When connecting flow and return pipes avoid to create mechanical stress onto the boiler flanges.

The boiler is not made to support the piping of the C.H. system, which needs dedicated supports. Once the complete C.H. system is finished, check for water leaks all the connections.

2.5.3 - CONNECTION OF FILLING AND DRAIN TAP

For the filling and drain of the boiler a dedicated tap can be connected to the

point T4, which is in rear part of the boiler.

2.5.4 - CONNECTION OF THE PRESSURE RELIEF VALVE

Fit onto the point T3 or onto the supply pipe, within 0.5 m from the flow flange, a pressure relief valve properly dimensioned for the

boiler capacity and in conformity with the local rules in force. It is forbidden to put any gate valve between the boiler and the pressure relief valve. The maximum working pressure of the boiler

is 5 bar for models TXN 65 - TXN 840 and 6 bar for models TXN 1100 - TXN 1900; the pressure relief valve has to be selected accordingly.

2.5.5 - CONNECTION OF THE EXPANSION PIPE AND VESSEL

An expansion vessel is always necessary, to compensate the water volume increase due to the heating. The TRIOPREX-N boilers are suitable for fully pumped systems, which can be open vented or sealed. In the 1st case the height of the hydrostatic column must be, at least, 3 m above the boiler casing and the capacity of the expansion cistern shall be able to contain, between the

water surface and the overflow pipe, the volume increase of all the water of the C.H. system. Preference shall be given to high and narrow cisterns, to expose to the air a surface as small as possible, thus reducing the water evaporation. In the 2nd case the vessel capacity has to be calculated taking into consideration:

- The total volume of the water contained in the system.
- The maximum working pressure of the system (see setting of PRV).
- The maximum working pressure of the

expansion vessel.

- The initial preloading of the expansion vessel.
- The maximum working temperature of the boiler (the maximum setting of the thermostat fitted onto the panel board is 90 °C; under this aspect it is suggested to consider 100 °C.

The expansion pipe connects the C.H. system to the expansion vessel. This pipe which starts from the connecting point T3 (see table DIMENSIONS), must have NO gate valve on it.

2.5.6 - SHUNT PUMP

The TRIOPREX-N boilers must always operate in forced circulation hot water systems and with a minimum return temperature of 55 °C. So, it is suggestable to adopt a shunt pump, having also an anti-condensation purpose, installed between the flow and return

connections, upstream an eventual 3 or 4 way mixing valve.
This pump will be sized according to the following formula:

$$Q = P \times 22$$

where **Q** = Water flow rate in liter/h
P = Boiler nominal output in kW
and the manometric head 1-2 m w.c.

2.6 - FURNACE DOOR: ADJUSTMENT, OPENING & CLOSING

A special attention has been paid to the design of the front door, because in all the pressurised boilers a good quality of the doors is a necessary condition for the best operation of the boiler.

With the furnace working in positive pressure, in fact, every minimum fissure could cause a leakage of high temperature combustion products, with consequent burning of the gasket and overheating of the door up to its permanent deformation.
For these reasons the door structure of the TRIOPREX-N boilers, in addition to the fact to be very strong, has also the possibility to

be adjusted: it can be lifted, lowered and also slanted, getting, thus, always the perfect centering of the sealing gasket.
The special inner lining in ceramic fiber reduces, furthermore, the time to reach the boiler steady state condition and then reduces drastically the formation of condensate at the boiler start.

2.6.1- IMPORTANT NOTE

Before opening the furnace door it is necessary to adopt the following precautions:

- Close the fuel cock (oil or gas) to the burner.
- Cool down the boiler by keeping the water

circulating through it, and only then switch off the power.

- Put on the boiler a Warning notice with the following text: DO NOT USE, BOILER

UNDER SERVICE, OUT OF ORDER.

2.7 - BURNER

2.7.1 - CONFORMITY OF THE BURNER

All the burners equipping the TRIOPREX-N boilers must be CE certificated and must conform to the following directives and standards:

- Gas Appliances Directive (90/396/CEE);
- EMC Directive (89/336/CEE).
- EN 267 - Automizing oil burners of monobloc type - Testing -
- EN 676 - Automatic forced draught burners for gaseous fuels.

2.7.2 - CHOICE OF THE BURNER

The correct choice and the adjustment of the burner are fundamental for the best operation of the boiler and then they shall be accurate and not underevaluated.

The burner will be selected by verifying that the working diagram (fuel flow rate - pressure in the furnace) is compatible with the same features declared for the boiler.

Remember that the smoke side resistance, i.e. the counterpressure in the furnace, are referred to "0" draught at the chimney base. It is also convenient that the burner blast tube have its length not shorter than that shown in the above table and that the flame have a shape suitable to the characteristics of the TRIOPREX-N furnace.

In fact to better exploit all the heating surface of the reversed flame furnace it is necessary to use burners capable to guarantee a long and narrow flame at all operating conditions or also at minimum input in case of two stage

BOILER TYPE	øA mm	L mm
TX N 65÷85	132	180
TX N 110÷150	132	180
TX N 185÷225	180	180
TX N 300÷380	180	200
TX N 500÷730	220	230
TX N 840	270	280
TX N 1100÷1320	270	320
TX N 1600÷1900	285	350

or modulating burners.

Too short flames can cause a localized overheating of the front part of the furnace, and the combustion products, not sufficiently cooled down, entering the smoke pipes at a too high temperature, can cause important damages to the boiler.

The burner manufacturing companies are able to supply the flame dimensions developed by their burners.

More informations are given in the paragraph "Commissioning".

2.7.3 - BURNER INSTALLATION

Before fitting the burner it is necessary to verify the position of the tubulators inside the

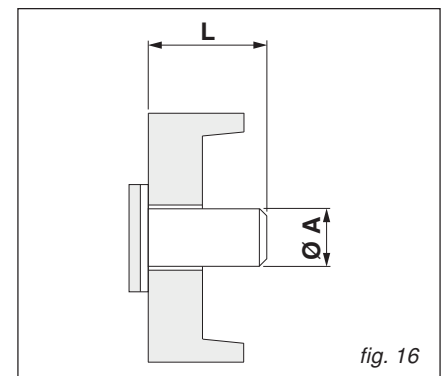

BURNER BLAST TUBE DIMENSIONS

smoke pipes: each pipe must have its turbulator and this one has to be positioned as indicated in the table on page 30.

When mounting the burner to the boiler front door, check for soundness around the burner flange and its gasket.

Each boiler is supplied with a length of ceramic fibre rope (cross section 25x25 mm).

This rope has to be put around the burner tube to completely seal the tube and the hole in the door insulation.

Be careful not to leave fissures between the burner tube and the hole in the door.

In case a cone, having a diameter larger than the burner tube, the cone is to be removed before fitting the burner and refitted later on. After the burner has been fitted, check that

the flexible hoses for the oil and the electrical cables are long enough to allow the 90° opening of the boiler door.

For gas burners the use of flexible pipes for the gas is not allowed; so the final part of the gas feeding line to the burner must have the possibility to be removed, via a threaded or flanged connection.

2.8 - CONNECTION OF THE SIGHTGLASS TO THE BURNER VIA A COOLING LINE

The flame sightglass is equipped with a 1/8" threaded connection (pos. 1) on which a pressure test nipple (9 mm dia.) is fitted. This can be used with a silicon pipe for the measurement of the counterpressure in the combustion chamber.

At the place of this pressure test nipple, which must be held, a special microbore pipe (pos. 2) will connect the flame sightglass directly to the pressure room downstream the fan of the burner.

The air, blown by the fan, will cool down and clean the sightglass.

If the sightglass is not cooled down it can be broken down.

WARNING: In the proximity of the sightglass the temperature is very high: be careful!!!

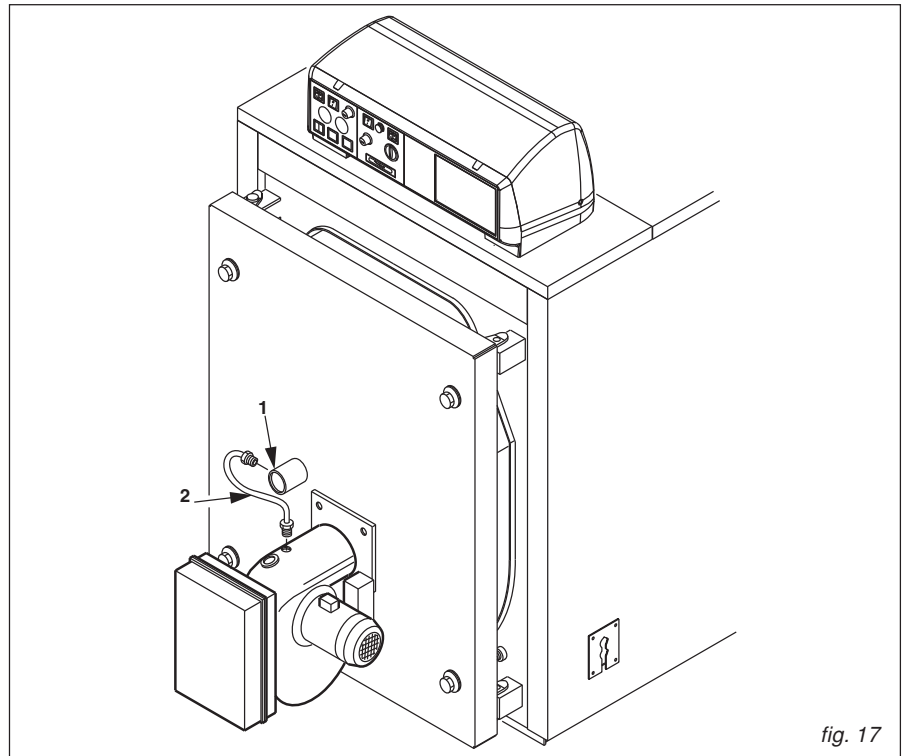

fig. 17

2.9 - CASING ASSEMBLY

N.B. It is suggested to verify that the boiler is positioned in its final place and that all the hydraulic connections are made correctly before starting the casing assembly. Before opening the casing carton(s) make

sure they are stamped with the right boiler model, corresponding to the boiler to be installed.

N.B.: The packaging containing the panel board is delivered inside the combustion chamber, as well as the documents and the guarantee certificate.

N.B. For the models TX-N 65 to TX-N 85 (ref. fig. 18 & 19), the casing and the insulation are contained in one carton stamped:	24123 (casing for TX-N 65) 24124 (casing for TX-N 85)	
N.B. For the models TX-N 110 to TX-N 380 (ref. fig. 20 & 21), the casing and the insulation are contained in one carton stamped:	24182 (casing TX N 110) 24183 (casing TX N 150) 24184 (casing TX N 185) 24185 (casing TX N 225)	24186 (casing TX N 300) 24187 (casing TX N 380)
N.B. For the models TX-N 500 to TX-N 730 (ref. fig. 22 & 23), the casing and the insulation are contained in 3 cartons stamped:	29609 (casing TX N 500) 29610 (casing TX N 500) 21064 (insulation TX N 500) 29611 (casing TX N 630) 29612 (casing TX N 630) 21065 (insulation TX N 630)	29613 (casing TX N 730) 29614 (casing TX N 730) 21066 (insulation TX N 730)
N.B. For the model TX-N 840 (ref. fig. 24 & 25), the casing and the insulation are contained in 3 cartons, stamped:	23016 (casing front side parts TX N 840) 23017 (casing rear side parts TX N 840) 23018 (casing upper parts TX N 840)	
N.B. For the models TX-N 1100 and TX-N 1600 (ref. fig. 26 & 27), the casing and the insulation are contained in four cartons, stamped:	22692 (casing front side parts TX N 1100) 22693 (casing rear side parts TX N 1100) 22694 (casing upper parts TX N 1100) 24031 (casing rear panel TX N 1100) 22692 (casing front side parts TX N 1320) 22696 (casing rear side parts TX N 1320)	22697 (casing upper parts TX N 1320) 24031 (casing rear panel TX N 1320) 22698 (casing front side parts TX N 1600) 22699 (casing rear side parts TX N 1600) 22700 (casing upper parts TX N 1600) 24032 (casing rear panel TX N 1600)
N.B. For the model TX-N 1900 (ref. fig. 28 & 29), the casing and the insulation are contained in 5 cartons, stamped:	22698 (casing front side parts TX N 1900) 22702 (casing rear side parts TX N 1900) 22703 (casing upper parts TX N 1900) 22704 (casing central parts TX N 1900) 24032 (casing rear panel TX N 1900)	

Assembly of the casing for TX-N 65 & 85 should be carried out in the following steps:
Refer to diagram on fig. 18 & 19 for details:

- | | | |
|--|---|--|
| <p>A) Fit the insulation blanket (1) onto the boiler shell and secure it in to place using the elasticated straps (2) provided, ensuring that the metal clips grip in to the external surface of the insulation.</p> <p>B) Locate the side panels (3) and (4) with the lower bend inside the bottom L profiles and the upper bend in the seats of front and rear tube plates.
To determine which is the left and right panel ensure that the cable glands are positioned facing toward the front edge.</p> <p>C) Fit the four screws pos. 5 on the front counter bend.</p> <p>D) Open the combustion chamber door and fit the front insulation (6), inserting the hinges in the pre-cuts.
Insert the side ends of the insulation under the bend of the two side panels (3 & 4).
Note: because the front insulation is suitable for two different boiler ranges (TX-N and</p> | <p>TS 3 P), before removing the precut insulation, follow the instructions supplied with the insulation it self.</p> <p>E) Fit the small panel (pos. 7) connecting the two side panels 3 & 4.</p> <p>F) After removal of the two side screws from the panel board rotate its cover frontwards and insert the cables and the capillaries of thermometer and thermostats through the slots on its base.
Fit the panel board to upper panel (8).
Fit the upper panel (8), complete with the panel board to the side panels (3 & 4).</p> <p>G) Insert the thermometer and thermostat bulbs in the bulb holders as shown in fig. 19 and connect the mains, the burner, the pump(s) and any ancillary equipment to the panel board.
Close the panel board.
Guide the burner plug through the side cable clamp plate (9) on the preferred side</p> | <p>and clamp the cable using the cable clamp supplied.
Fix the side cable clamp plates (9) to the casing side panels (3 & 4).
Fit the cable clamp (pos. 12) onto the rear bend of a side panel, pos. 3 or 4.
Fit the cables, leaving the boiler from the back side, with the plastic screws of the cable clamps (12).</p> <p>H) Fit the rear insulation (pos. 10), fix the rear lower panel (pos. 11) with the self tapping screws.</p> <p>I) Remove the protective paper film from data plate and ventilation requirement label and fit them at the top front corner of the most accessible side panel after removal of dust from the surface.
The data plate and label are in the documents envelope.</p> |
|--|---|--|

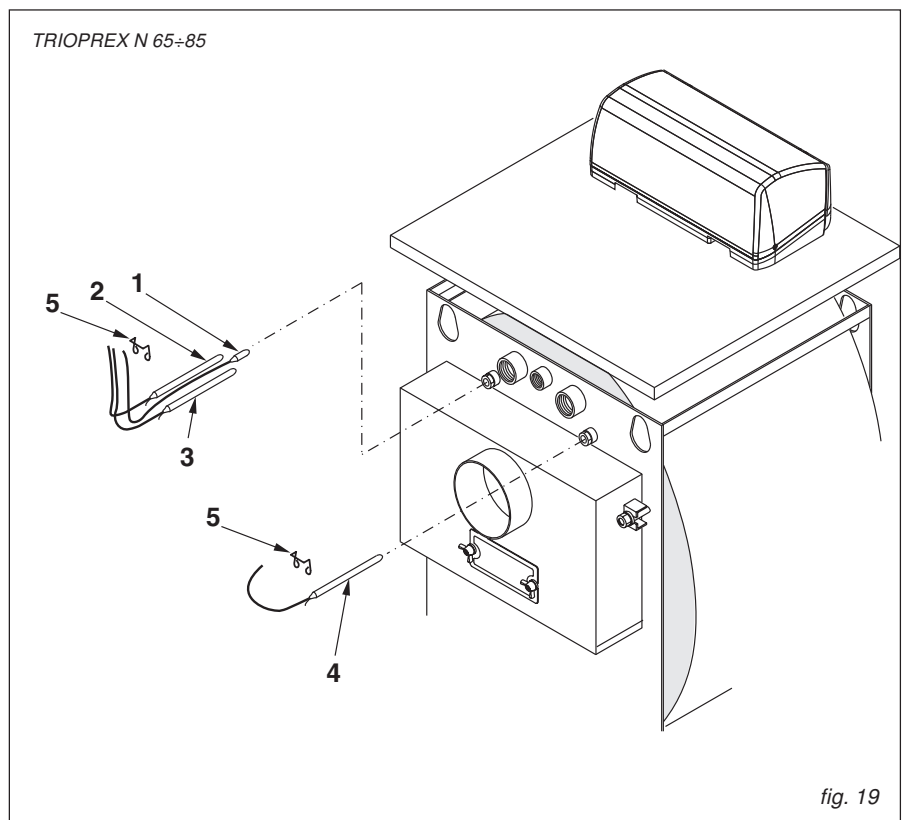
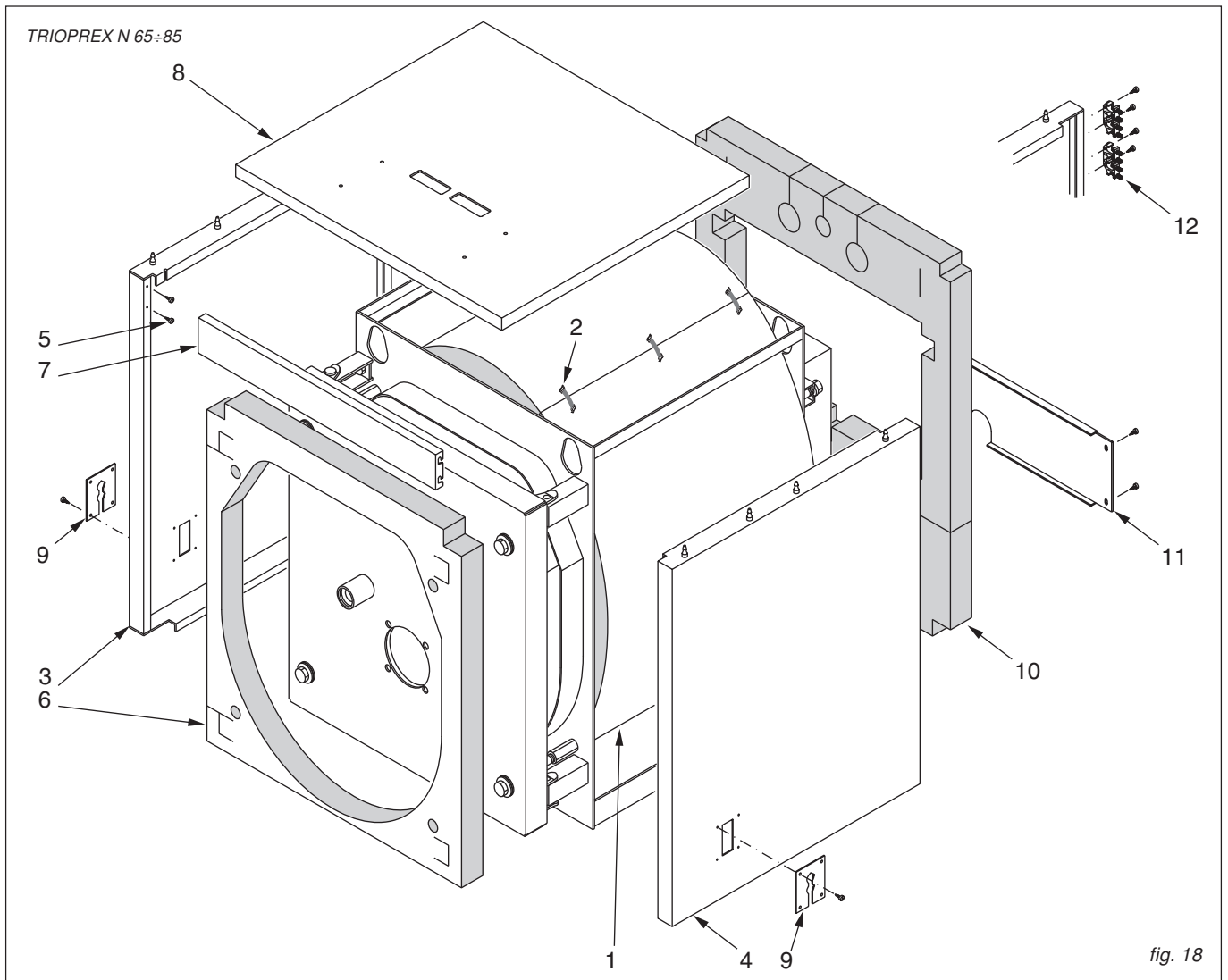

- 1 Thermometer bulb
- 2 Working thermostat bulb
- 3 Minimum thermostat bulb
- 4 Safety thermostat bulb
- 5 Bulb retaining clip

Assembly of the casing for TX-N 110 to 380 should be carried out in the following steps:
Refer to diagram on fig. 20 & 21 for details:

- A) Fit the insulation blanket (1) onto the boiler shell and secure it in to place using the elasticated straps (2) provided, ensuring that the metal clips grip in to the external surface of the insulation.
- B) Locate the side panels (3) and (4) with the lower bend inside the bottom L profiles and the upper bend in the seats of front and rear tube plates.
 To determine which one is the left or right hand side panel ensure that the cable glands are positioned facing toward the front edge.
- C) Open the combustion chamber door and fit the front insulation (5), inserting the hinges in the pre-cuts.
 Insert the side ends of the insulation under the bend of the two side panels (3 & 4).
- D) Fit the rear insulation (pos. 6), fix the rear lower, intermediate and upper panels (pos. 7, 15 & 8) with the self tapping screws.
 Fit the plastic cable clamps (9) to the upper rear panel (8).
 Note: because the rear insulation is suitable for two different boiler ranges (TX-N and TS 3 P), before removing the precut insulation, follow the instructions supplied with the insulation it self.
- E) After removal of the two side screws from the panel board rotate its cover frontwards and insert the cables and the capillaries of thermometer and thermostats through the slots on its base.
 Fit the panel board to front upper panel (10).
 Fit the upper front panel (10), complete with the panel board to the side panels (3 & 4).
- F) Insert the thermometer and thermostat bulbs in the bulb holders as shown in fig. 21 and connect the mains, the burner, the pump(s) and any ancillary equipment to the panel board.
 Close the panel board.
 Guide the burner plug through the side cable clamp plate (11) on the preferred side and clamp the cable using the cable clamp supplied.
 Fix the side cable clamp plates (11) to the casing side panels (3 & 4).
 Fit the cables, leaving the boiler from the back side, with the plastic screws of the cable clamps (9).
- G) Fit the longitudinal upper panels (pos. 12 and 13) to the side panels.
- H) Remove the protective paper film from data plate and ventilation requirement label (14) and fit them at the top front corner of the most accessible side panel after removal of dust from the surface.
The data plate and label are in the documents envelope.

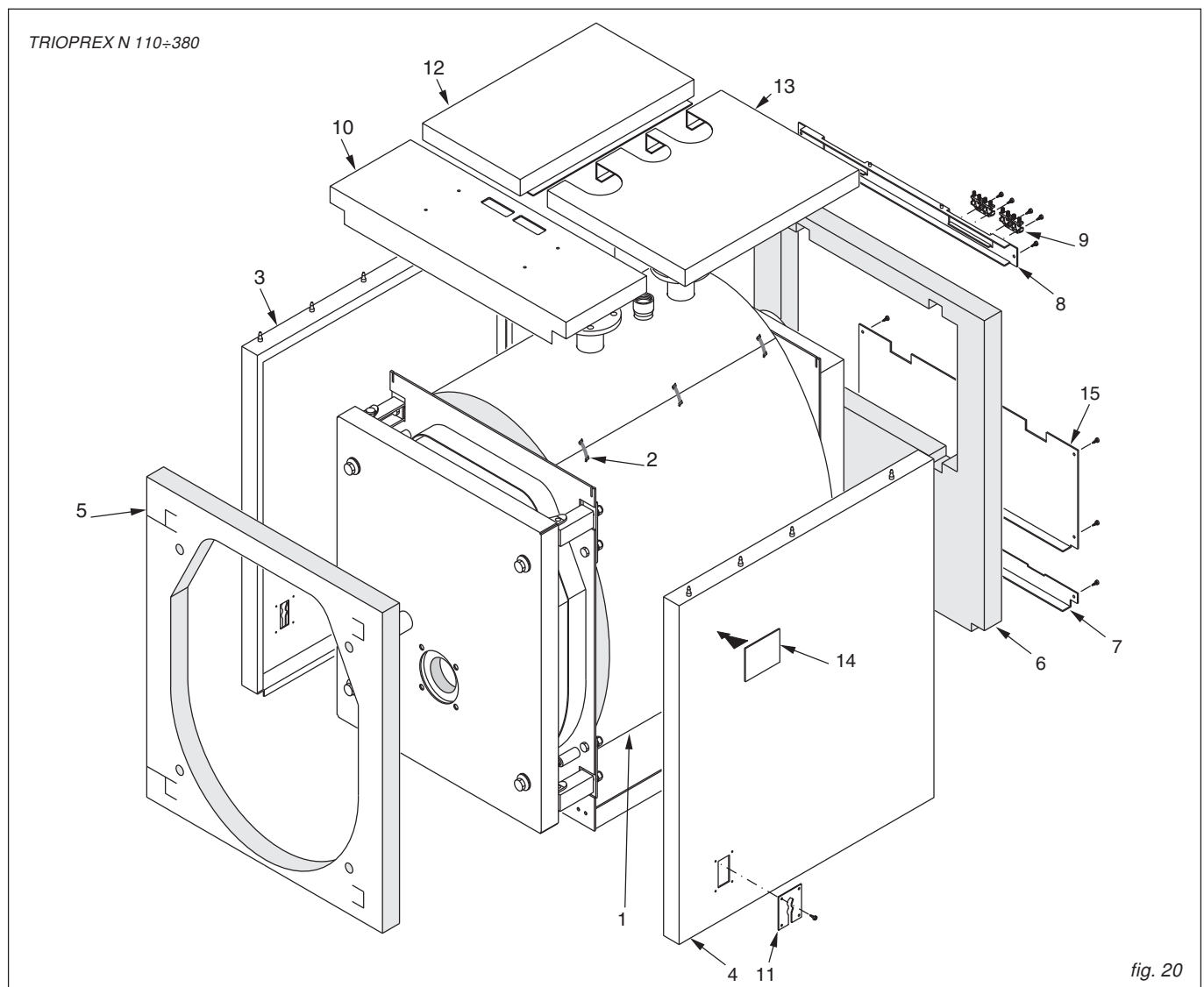
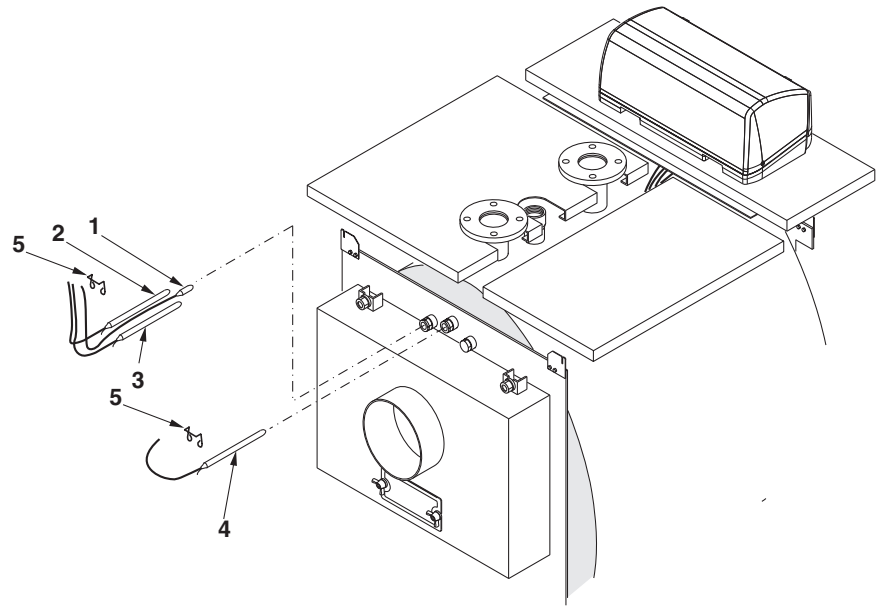

fig. 20



- 1 Thermometer bulb
- 2 Working thermostat bulb
- 3 Minimum thermostat bulb
- 4 Safety thermostat bulb
- 5 Bulb retaining clip

fig. 21

**Casing mounting sequence for TX-N 500/730
(Ref. figs. 22 and 23)**

- A) Fit to the front and rear tube plates the four upper brackets (pos. 1), supporting the side panels, using the screws, washers and nuts supplied (pos. 2, 3 and 4).
- B) Fit to the front and rear tube plates the four intermediate and lower brackets (pos. 5) supporting the side panels, using the screws, washers and nuts supplied (pos. 2, 3 and 4).
- C) Fit the insulation blanket (6) onto the boiler shell and secure it in to place using the elasticated straps (7) provided, ensuring that the metal clips grip in to the external surface of the insulation.
- D) Position the side lower panels (pos. 9 and 18) onto the lower and intermediate brackets (pos. 5).
To determine which one is the left or right hand side panel ensure that the cable glands are positioned facing toward the front edge.
- E) Position the side upper panels (pos. 8 and 17) onto the upper brackets (pos. 1) and fix their pivots on the lower side.
- F) Fit the 8 screws (pos. 10) to the upper part of the front and rear counter bend of the upper panels (pos. 8 and 17).
- G) Fit the front insulation (pos. 11), inserting the hinges in the insulation pre-cuts.
Note: because the front insulation is suitable for two different boiler ranges (TX-N and TS 3 P), before removing the precut insulation, follow the instructions supplied with the insulation it self.
- H) Fit the rear insulation (pos. 16) and fix the rear lower panel (pos. 26).
- I) Position the panels 12 and 19 between the side upper panels (pos. 8 and 17).
- L) After removal of the two side screws from the panel board rotate its cover frontwards and insert the cables and the capillaries of thermometer and thermostats through the slots on its base.
Fit the panel board to front upper panel (13).
Fit the upper panel (13), complete with the panel board to the side upper panels (8 & 17).
Guide the burner plug through the side cable clamp plate (14) on the preferred side and clamp the cable using the cable clamp supplied.
Fix the side cable clamp plates (14) to the casing side panels (9 & 18).
Fit the cable clamps (pos. 20) onto the rear panel (pos. 19).
Fit the cables, leaving the boiler from the back side, with the plastic screws of the cable clamps (20).
- M) Insert the thermometer and thermostat bulbs in the bulb holders as shown in fig. 23 and connect the mains, the burner, the pump(s) and any ancillary equipment to the panel board.
Close the panel board.
- N) Fit the longitudinal upper panels (pos. 21 and 25) to the side panels.
- O) Remove the protective paper film from data plate and ventilation requirement label and fit them at the top front corner of the most accessible side panel after removal of dust from the surface.
The data plate and label are in the documents envelope.

TRIOPREX N 500÷730

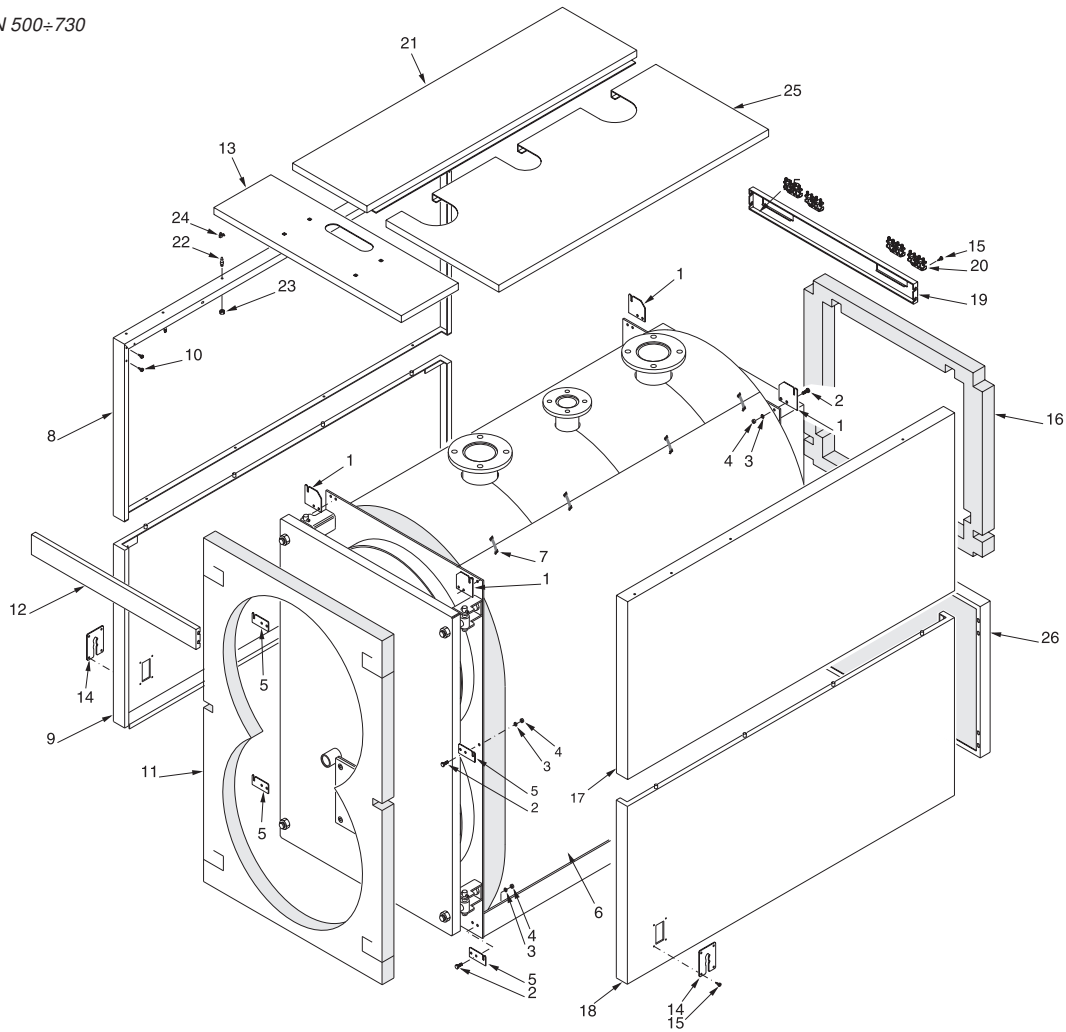
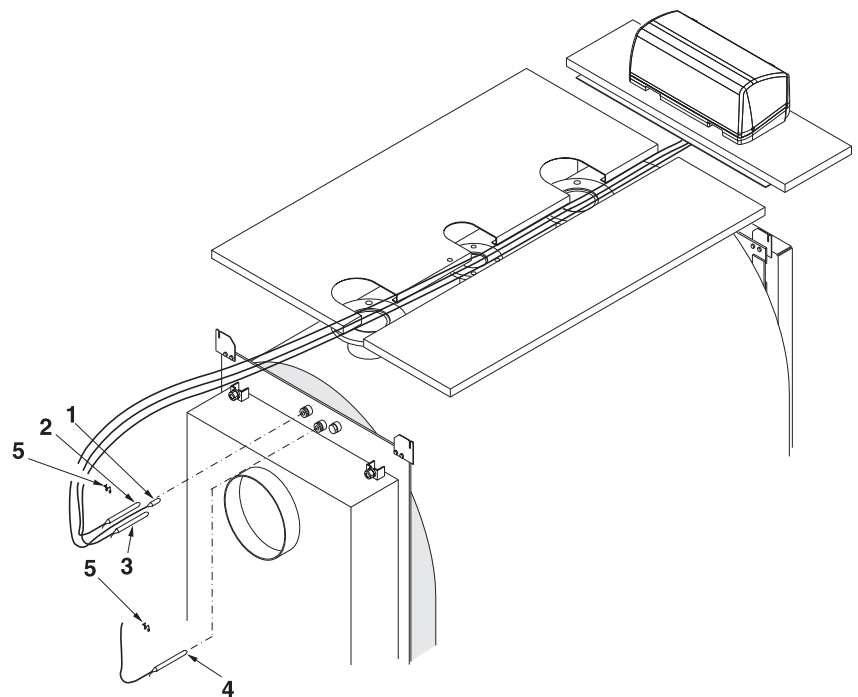

fig. 22

TRIOPREX N 500÷730



- 1 Thermometer bulb
- 2 Working thermostat bulb
- 3 Minimum thermostat bulb
- 4 Safety thermostat bulb
- 5 Bulb retaining clip

fig. 23

**Casing mounting sequence for TX N 840
(Ref. figs. 24 and 25)**

- A) Fit the insulation blanket (1) onto the boiler shell and secure it in to place using the elasticated straps (2) provided, ensuring that the metal clips grip in to the external surface of the insulation.
- B) Locate the side panels (pos. 3, 4, 5 and 6) hooking them to the upper and lower profiles.
To determine which one is the left or right hand side front panel ensure that the cable glands are positioned facing toward the front edge.
- C) Fit the four screws pos. 7 on the inner upper rear side panels.
- D) Open the combustion chamber door and fit the front insulation (pos. 8), inserting the hinges in the insulation pre-cuts.
Note: because the front insulation is suitable for two different boiler ranges, before removing the pre-cut insulation, follow the instructions supplied with the insulation it self.
- E) After removal of the two side screws from the panel board rotate its cover frontwards and insert the cables and the capillaries of thermometer and thermostats through the slots on its base.
Fit the panel board to front upper panel (9).
Fit the upper panel (9), complete with the

- panel board to the side upper panels (3 & 5).
Guide the burner plug through the side cable clamp plate (16) on the preferred side and clamp the cable using the cable clamp supplied.
Fix the side cable clamp plates (16) to the casing side panels (3 & 5).
Fit the cables, leaving the boiler from the back side, with the plastic screws of the cable clamps (15).
- F) Insert the thermometer and thermostat bulbs in the bulb holders as shown in fig. 25 and connect the mains, the burner, the pump(s) and any ancillary equipment to the panel board.
Close the panel board.
Guide the burner plug through the side cable clamp plate (16) on the preferred side and clamp the cable using the cable clamp supplied.
- G) Fit the longitudinal upper panels (pos. 10 and 11) to the side panels.
- H) Fit the rear insulation (pos. 12) and fix the rear lower panel (pos. 13).
- I) Fit the rear upper panel (pos. 14).
- L) Fit the plastic cable clamps (pos. 15) onto the rear upper panel (pos. 14).
Fit the cables, leaving the boiler from the back side, with the plastic screws of the

- cable clamps (15).
- M) Remove the protective paper film from data plate and ventilation requirement label and fit them at the top front corner of the most accessible side panel after removal of dust from the surface.
The data plate and label are in the documents envelope.

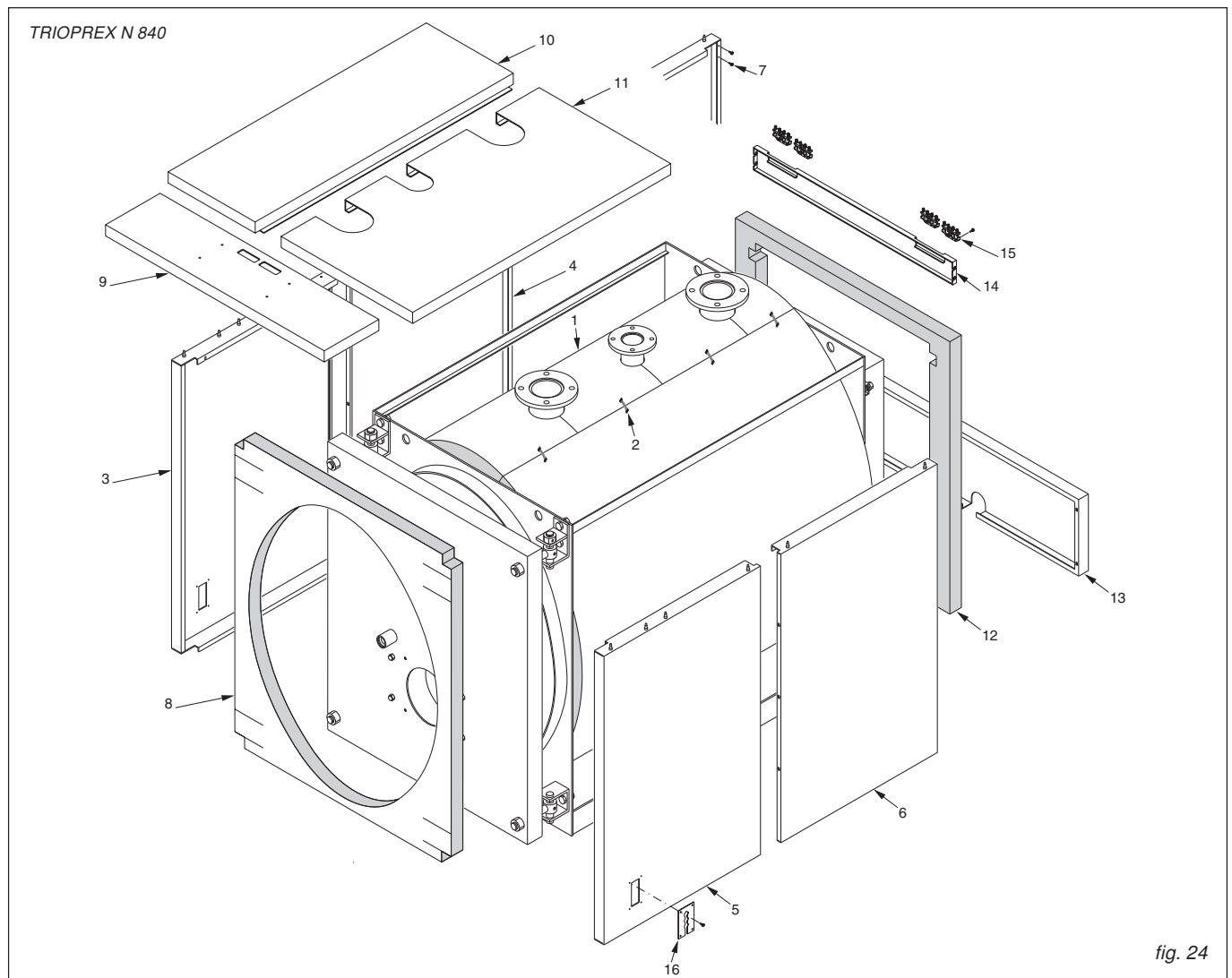

fig. 24

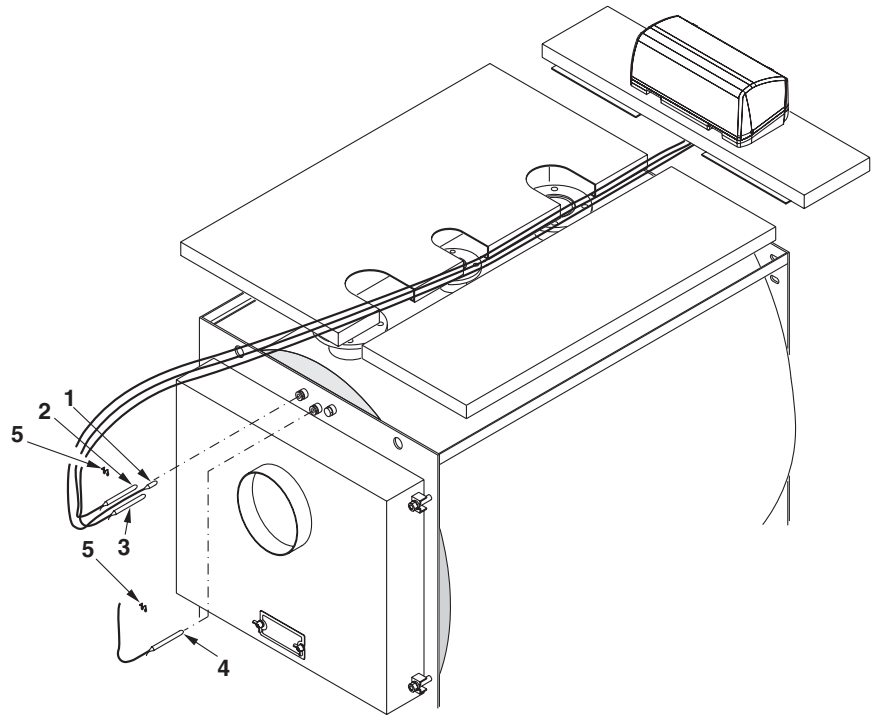

fig. 25

- 1 Thermometer bulb
- 2 Working thermostat bulb
- 3 Minimum thermostat bulb
- 4 Safety thermostat bulb
- 5 Bulb retaining clip

Sequence of bulbs introduction

Introduce the bulbs into the bulb holder, in the upper part of the boiler body, in the following sequence (Ref. to fig. 26):

- (pos. 1) thermometer
 - (pos. 2) working thermostat
 - (pos. 3) high limit thermostat
 - (pos. 4) minimum temperature thermostat.
- It is recommended to introduce the bulbs up to the bottom of the bulb holder to have a better response. Introduce then the contact spring (pos. 6) to improve the contact and secure the capillaries in position by the clip (pos. 5).

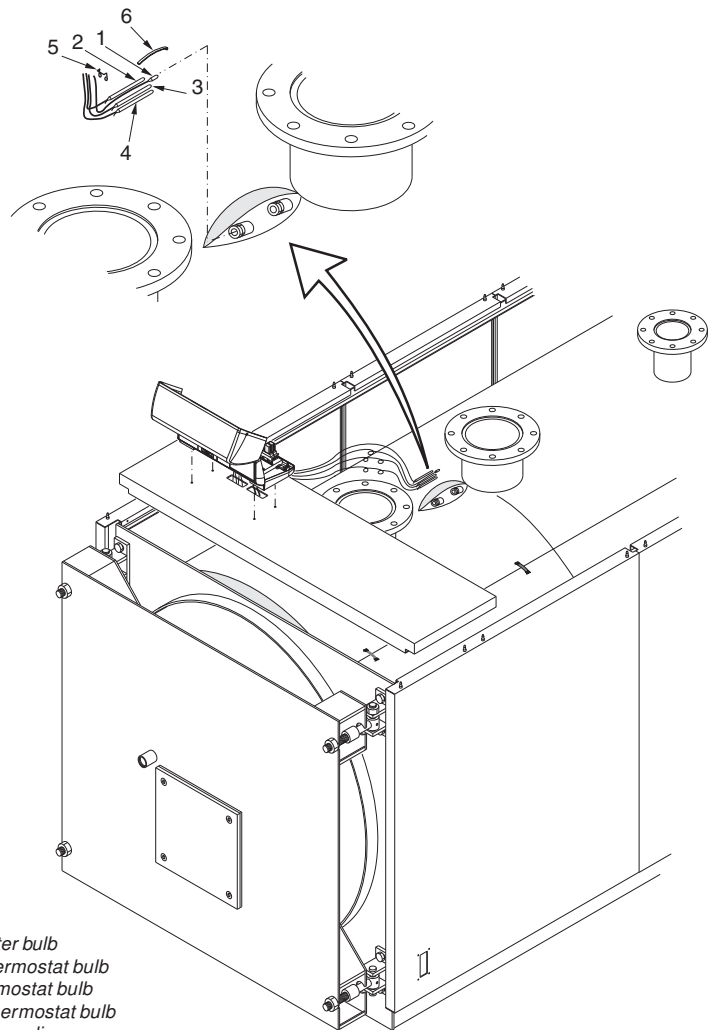

- 1 Thermometer bulb
- 2 Working thermostat bulb
- 3 Safety thermostat bulb
- 4 Minimum thermostat bulb
- 5 Bulb retaining clip
- 6 Contact spring

fig. 26

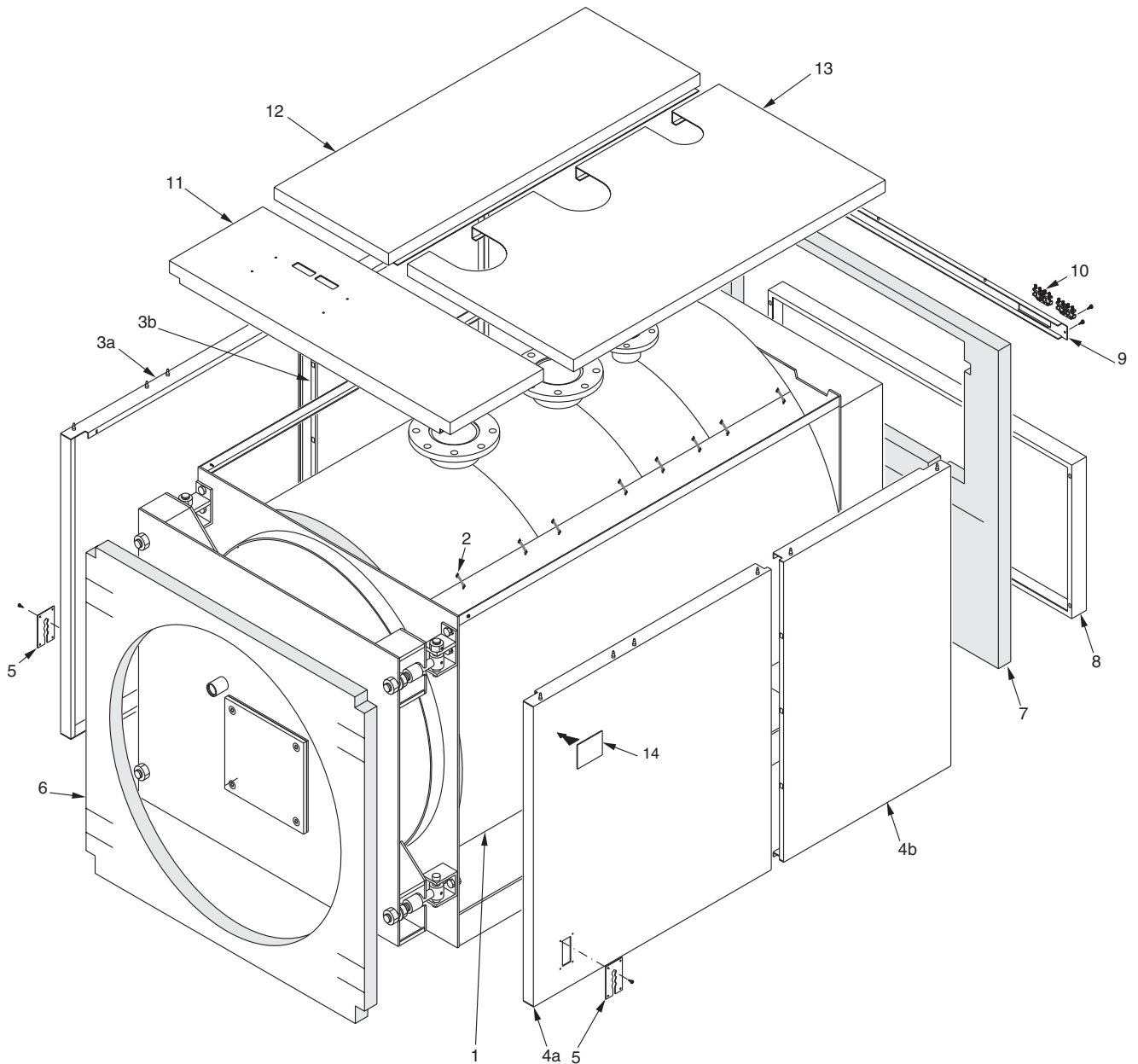

fig. 27

Casing mounting sequence for TX-N 1100/1900 (Ref. figs. 26 & 27)

- A) Fit the insulation blanket (1) onto the boiler shell and secure it in to place using the elasticated straps (2) provided, ensuring that the metal clips grip in to the external surface of the insulation. Make a convenient cut in the upper part of the insulation blanket to get easy access to the bulb holders.
- B) Position the side panels (3a, 3b and 4a, 4b) with the lower bend inside the bottom L profiles and hook them to the screws fitted to the upper profiles. To determine which one of the front side panels is the left or the right ensure that the cable clamp plates (5) are positioned facing toward the front edge.
- C) Open the combustion chamber door and fit the front insulation (pos. 6), inserting the hinges in the insulation pre-cuts.
- D) Fit the rear insulation (pos. 7) and fix the rear lower panel (pos. 8) .
- E) Fit the rear upper panel (pos. 9) and fit onto it the plastic cable clamp (pos. 10).
- F) After removal of the two side screws from the panel board rotate its cover frontwards and insert the cables and the capillaries of thermometer and thermostats through the slots on its base. Fit the panel board to front upper front panel (11). Fit the upper front panel (11), complete with the panel board to the side panels (3a & 4a).
- G) Insert the thermometer and thermostat bulbs in the bulb holders as shown in fig. 26 and connect the mains, the burner, the pump(s) and any ancillary equipment to the panel board. Close the panel board.
- H) Fit the longitudinal upper panels (pos. 12 and 13) to the side panels.
- I) Remove the protective paper film from data plate and ventilation requirement label (12) and fit them at the top front corner of the most accessible side panel after removal of dust from the surface. **The data plate and label are in the documents envelope.**

Electrical cables positioning

The panel board Standard or with outer compensator) is equipped with a burner cable, a PG 11 gland (pos. 2) and a 7 pole plug (pos. 3) - See wiring diagrams on figs. 30 and 31.

When fitting the panel board the leads of the burner cable, which has to be passed through the cable gland, must be connected to the panel board terminal strip (see wiring diagrams on figs. 30 & 32).

The seven pole plug and the cable must come out from the casing through the cable clamp plate (pos. 1), onto which the cable gland (pos. 2), onto which the cable gland must be fixed.

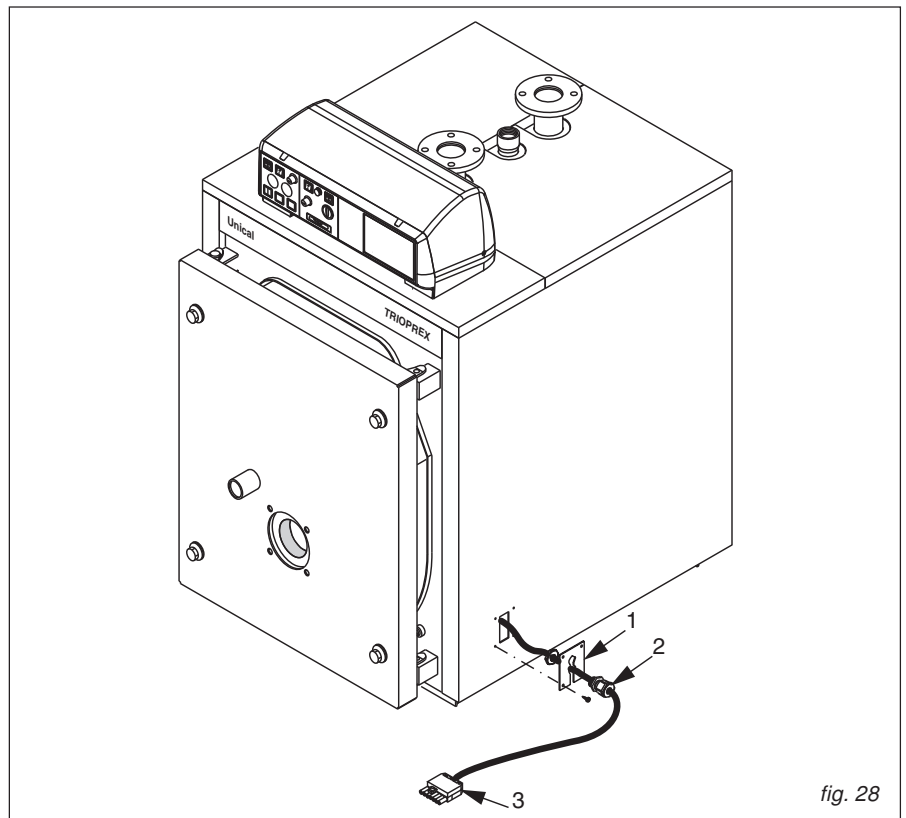

fig. 28

3

STANDARD PANEL BOARD

3.1 - PANEL BOARD TYPE 21056

(mod. TX N 65÷TX N 185).

PANEL BOARD TYPE 21057

(mod. TX N 225÷TX N 1900).

FUNCTIONS DESCRIPTION

Through the main switch [11] the panel board and all the equipments connected to it will be under power.

The switches [12] & [13] switch On and OFF the power to the burner and the Heating pump (via a relay, if necessary).

With the thermostat [32] the working temperature of the boiler can be adjusted. This thermostat is provided with a DPDT contact, for the control of a two stage burner. The differential between the switching points of the two double pole is 6 °C (not adjustable). The minimum thermostat, accessible through the opening of the panel board cover, switches OFF the C.H. pump during the reacing of the steady state and up to the obtention of 50 °C within the boiler.

On the electrical supply line to the boiler a switch with fuses is to be foreseen.

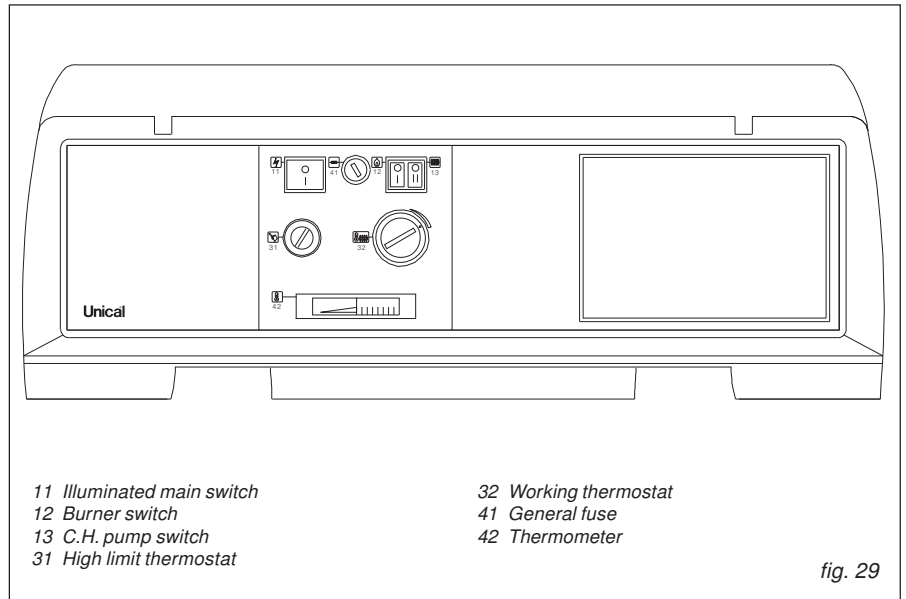

fig. 29

3.2 - ELECTRICAL WIRING DIAGRAM FOR SINGLE PHASE BURNER AND PUMP

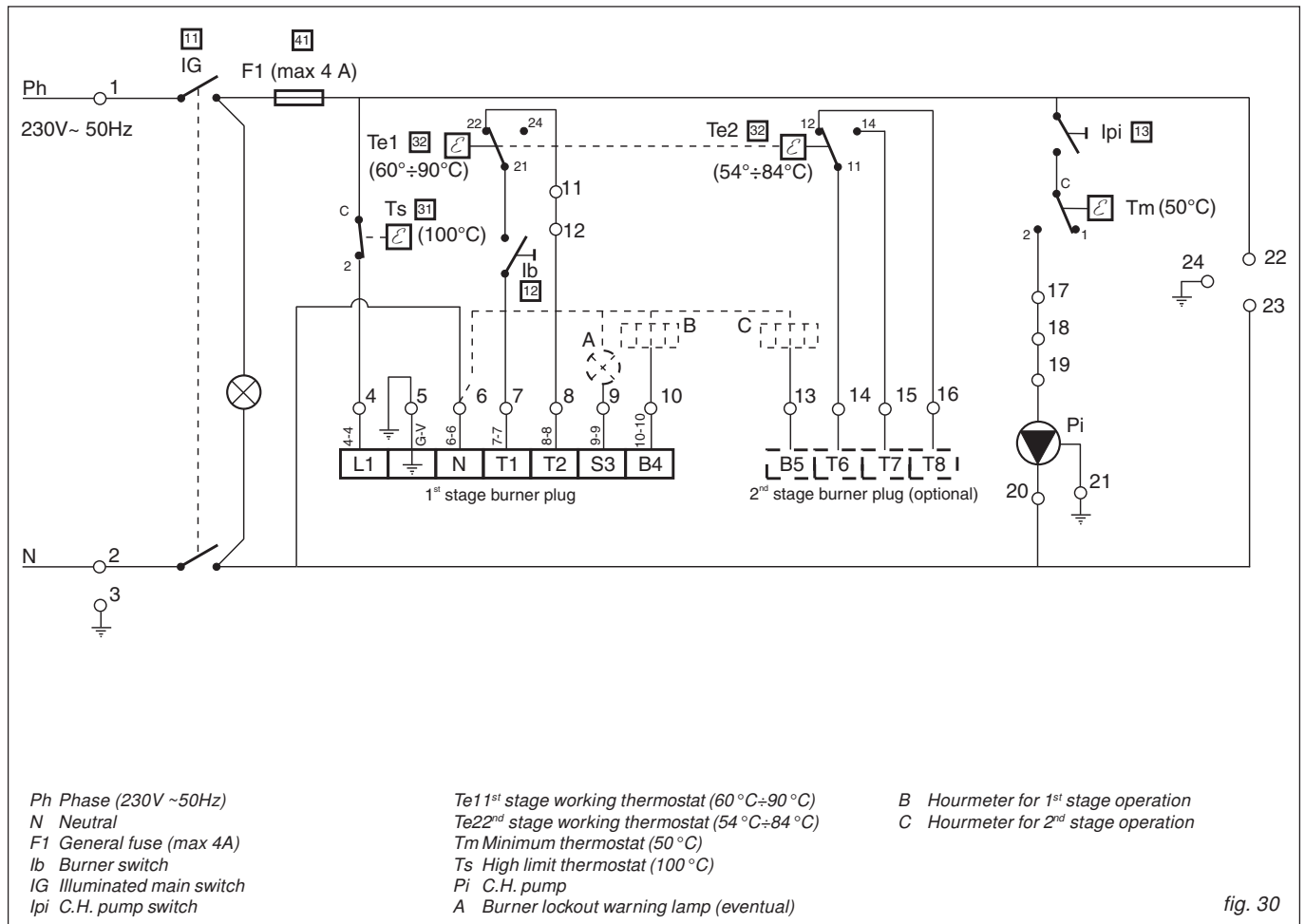

fig. 30

3.3 - INTRODUCTION OF THE ELECTRONIC PANEL BOARD TYPE 30688

The TRIOPREX-N boilers can be supplied with an electronic panel board complete with a digital outer compensator with built-in microcomputer and permanent memory. The management of the boiler is made through the outer compensator which, in addition to the burner and pump control, can control also two different heating zones.

The automatic operation is made on the base of the data detected by the boiler, D.H.W. storage tank, outer, room and flow temperature sensors. This last sensor will be fitted only when a mixing valve is fitted.

The outer compensator is capable to control several heating system configurations:

- one direct zone C.H. system without mixing valve: the flow sensor has not to be fitted; the outer compensator controls only the pump of the C.H. system No. 1.
- one zone C.H. system with mixing valve: the flow sensor has to be fitted downstream the mixing valve; the outer compensator controls the pump of the C.H. system No. 2.
- two zone C.H. system: one direct and one with mixing valve; the outer compensator

controls the direct pump of the C.H. system No. 1, the mixing valve and the pump of the mixed C.H. system No. 2.

The outer compensator sensors (boiler, storage tank, outer and flow) are included in the supply; the room sensors for the C.H. systems No.1 and No. 2 are optionals.

The mixing valve and the relevant motor are not supplied by Unical.

When the room sensor is not fitted (it is optional), the room temperature is determined and controlled only by the heating curve of the outer compensator program.

The electronic panel board type 30688 is supplied as standard with the outer compensator, type 30680, already fitted.

If two boilers in cascade are fitted, please get in touch with our after sale service.

3.4 - PANEL BOARD TYPE 30688 DESCRIPTION OF FUNCTIONS

Through the main switch [11] the panel board and the ancillary equipments connected to it are powered.

The switches [12] and [13] control the respectively the burner and the heating pump of the mixed zone.

The switches [14] and [15] control the heating pump of the direct zone and the storage tank pump.

Through the thermostat [32] the boiler working temperature is adjusted.

The minimum temperature thermostat, placed under the plug [34] keeps OFF the heating pump during the starting of the boiler till the boiler temperature reaches 30°C.

On the supply line to the boiler panel board a double pole fused switch has to be fitted.

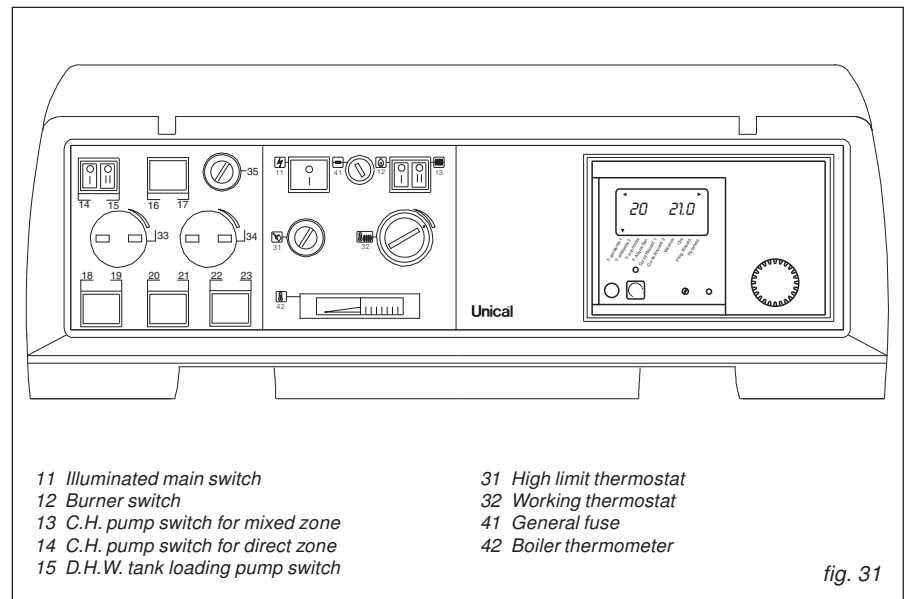

- 11 Illuminated main switch
- 12 Burner switch
- 13 C.H. pump switch for mixed zone
- 14 C.H. pump switch for direct zone
- 15 D.H.W. tank loading pump switch

- 31 High limit thermostat
- 32 Working thermostat
- 41 General fuse
- 42 Boiler thermometer

fig. 31

3.5 - ELECTRICAL WIRING DIAGRAM FOR SINGLE PHASE BURNER AND PUMPS

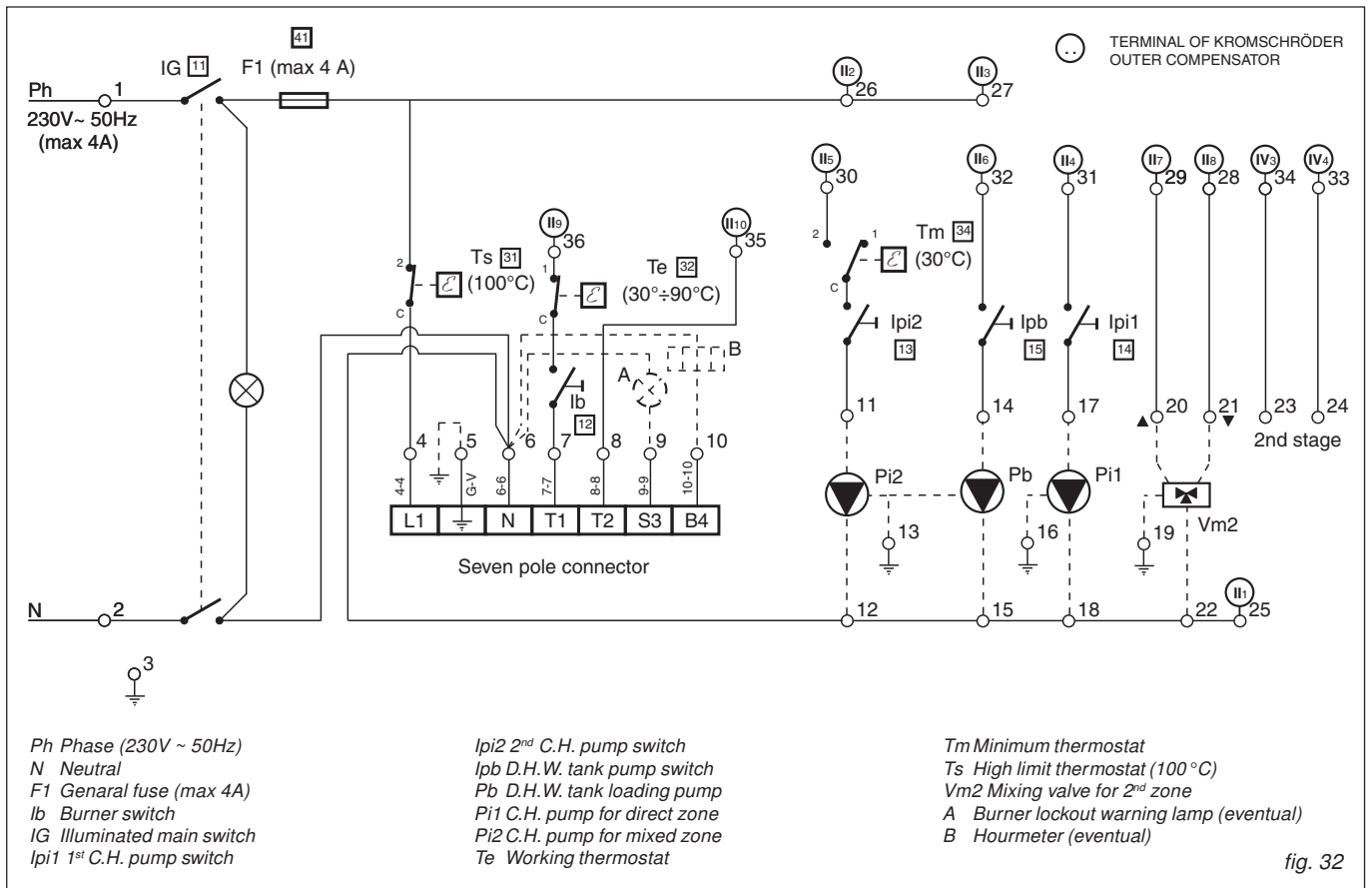

SENSOR CONNECTION ONTO THE OUTER COMPENSATOR TERMINAL STRIP

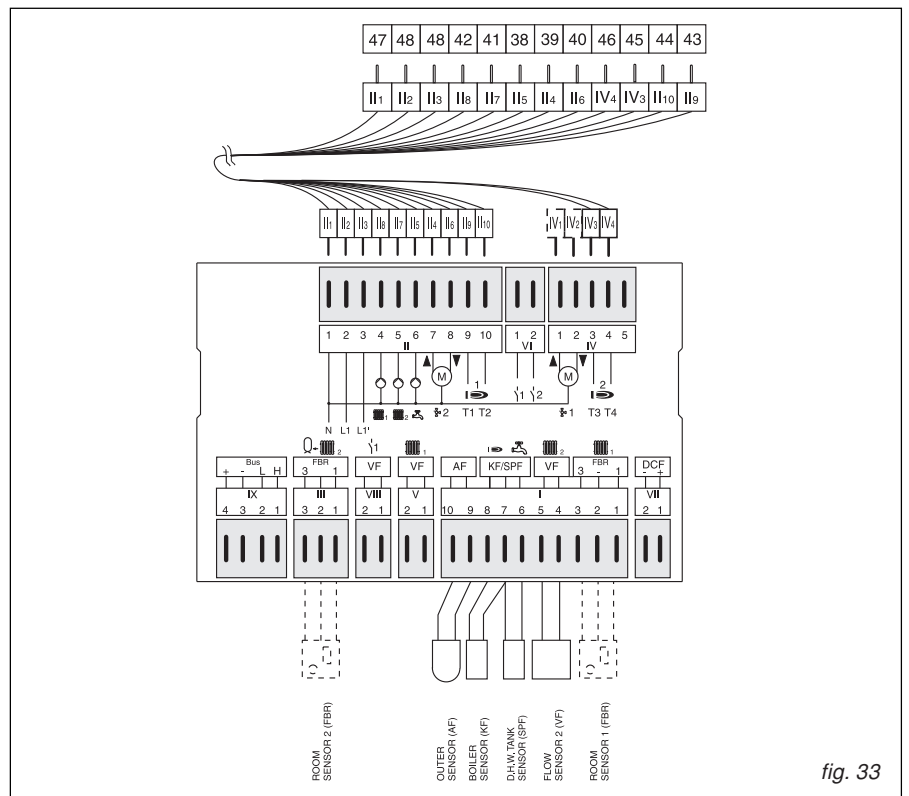

3.6 - OUTER COMPENSATOR

On how to adjust or to program the outer compensator, please refer to the instruction manual supplied with the outer compensator. In the following table we list the factory set

parameters, which are "not changeable" and the parameters which are adjustable by the user according to his needs.

PARAMETERS PROGRAMMABLE BY A TECHNICIAN AND PROTECTED BY AN ACCESS CODE

INSTALLATION			
Designation	Value range	Default	IV
CODE-NO	0000 - 9999	ENTRY	
CODE-NO (Adjustment)	0000 - 9999	0000	
BUS ID 1	(00), 01 - 15	01	
BUS ID 2	(00), 01 - 15	02	
AF SUPPLY	00,01 (OFF/ON)	01 = ON	
TIME MASTER	00, 01 (OFF / ON)	00 = OFF	
T-HS MAX	30 °C - 110 °C	80 °C	
MIN T-HS	10 °C - 80 °C	60 °C	
WARM-UP-T	10 °C - 85 °C	50 °C	
MIN-DELIMI	00, 01, 02	00	
HYSTERESIS	5K - 20K	5 gradi	
HYST TIME	00 min - 30 min	10 min	
DELAY ST	00 min - 30 min	10 min	
HYST BURNER 2	2K - 20K	2K	
SEQ CHANGE (*)	0h - 250h	0h (*)	
RELAY FUNC 1	00 - 08	00	
RELAY-TEMP 1	30 °C - 90 °C	30 °C	
HYST RELAY 1	2K - 10K	5K	
RELAY FUNC 2	00 - 03	00	
SCREED	00 - 01 (OFF / ON)	00 = OFF	
SCREED PROGR	See explanation!		
RETURN	Exit level using 		

* The switching time of the parameter SEQ CHANGE (Sequence change) can be adjusted up to 250 h only if the controller is used for controlling two boilers equipped with a single-stage burner each.

If the controller is used for controlling a boiler with a two-stage burner, the parameter SEQ CHANGE must be left at "0 h".

It must be left also at "0 h" if the controller is used for controlling two boilers, of which one, for instance, has a better efficiency and, the second one, is used only when the first one is out of order or is not capable to supply, alone, the total heat necessary for the heating system.

HOT WATER			
Designation	Value range	Default	IV
CP LOCK	00 - 01 (OFF / ON)	01 = ON	
PARALLEL	00 , 01, 02, 03	00	
HS-T DHW	00 °C - 50 °C	20 °C	
HYST DHW	5K - 30K	5K	
DHW FOLLOWUP	00 min - 30 min	00 min	
THERM INPUT	00, 01 (OFF / ON)	00 = OFF	
CHARGE THROUGH	00, 01 (OFF / ON)	00 = OFF	
RETURN	Exit level using 		

HEATING CIRCUIT 1			
Designation	Value range	Default	IV
HC FUNCTION	00 - 04	00	
PUMP MODE	00 , 03	00	
MIXER OPEN (not for HW circuit)	5 - 25	16	
MIXER CLOSE (not for HW circuit)	5 - 25	12	
MAX FLOW-T	20 °C - 110 °C	80 °C	
MIN FLOW-T	10 °C - 110 °C	10 °C	
FROST PROT	---- (-15)°C - (5)°C	0 °C	
OUT-TEMP-DEL	0:00 - 24:00	1	
SLOPE OFFSET	0K - 50K	5K	
B-HEAT SINK	00 - 01 (OFF / ON)	01 = ON	
RETURN	Exit level using 		

HEATING CIRCUIT 2			
Designation	Value range	Default	IV
HC FUNCTION	00 - 04	00	
PUMP MODE	00 , 03	00	
MIXER OPEN (not for HW circuit)	5 - 25	16	
MIXER CLOSE (not for HW circuit)	5 - 25	12	
MAX FLOW-T	20 °C - 110 °C	45 °C	
MIN FLOW-T	10 °C - 110 °C	10 °C	
FROST PROT	---- (-15)°C - (5)°C	0 °C	
OUT-TEMP-DEL	0:00 - 24:00	1	
SLOPE OFFSET	0K - 50K	5K	
B-HEAT SINK	00 - 01 (OFF / ON)	01 = ON	
RETURN	Exit level using 		

PARAMETERS PROGRAMMABLE BY THE USER

PARAMETERS DISPLAYED AT THE COMMISSIONING STAGE	
Start INSTALLATION, Set value, Save value and next value	
GERMAN	Set language
TIME	Set current time: 1. Minute => => 2. Hour
YEAR	Set current date
MONTH	Set current date
DAY	Set current date
BUS ID 1	Enter heating circuit number "1": 00-15 => Standard 01
BUS ID 2	Enter heating circuit number "2": 00-15 => Standard 02
5K SENSOR	00 = 5 KOhm NTC sensor 01 = 1 kOhm PTCsensor, code no. required; after input, there is a restart of the controller
RETURN	end of INSTALLATION

INSTALLATION			
Start INSTALLATION, Set value, Save value and next value			
Designation	Value range	Default	IV
GERMAN	Acc. to version	GERMAN	
CONTRAST	(-20) (20)	0	
DISPLAY SEL	Sensor, weekday	----	
RETURN	Exit level using		

HOT WATER			
Designation	Value range	Default	IV
1X DHW	00, 01 (OFF / ON)	00 = OFF	
DHW-TEMP 1	10 °C - 70 °C	60 °C	
DHW-TEMP 2	10 °C - 70 °C	60 °C	
DHW-TEMP 3	10 °C - 70 °C	60 °C	
BOB-VALUE	OK - 70K	0K	
CIRCL-P-DHW	00, 01 (OFF / ON)	00 = OFF	
ANTILEGION	00, 01 (OFF / ON)	00 = OFF	
RETURN	Exit level using		

HEATING CIRCUIT 1			
Designation	Value range	Default	IV
MODE	---- ⏻, 1 2 * 🌙	----	
T-ROOM DES 1*)	5 °C - 40 °C	20 °C	
T-ROOM DES 2	5 °C - 40 °C	20 °C	
T-ROOM DES 3	5 °C - 40 °C	20 °C	
ECONO TEMP *)	5 °C - 40 °C	10 °C	
REDUCED TEMP	5 °C - 40 °C	15 °C	
T-LIMIT DAY	----, (-5) °C - 40 °C	19 °C	
T-LIMIT N	----, (-5) °C - 40 °C	10 °C	
HEAT SLOPE	0,00 - 3,00	1,20	
ADAPTION	00, 01 (OFF / ON)	00 = OFF	
ROOMS-INFL	00 - 20	10	
ADAP ROOM-T	(-5,0)K - (5,0)K	0,0K	
OPTIMIZAT	00, 01, 02	00	
M-OPT-TIME	0:00 - 3:00 (h)	2:00 (h)	
ECONO OPTI	0:00 - 3:00 (h)	0:00 (h)	
PC-ENABLE	0000 - 9999	0000	
RETURN	Exit level using 		

HEATING CIRCUIT 2			
Designation	Value range	Default	IV
MODE	---- ⏻, 1 2 * 🌙	----	
T-ROOM DES 1*)	5 °C - 40 °C	20 °C	
T-ROOM DES 2	5 °C - 40 °C	20 °C	
T-ROOM DES 3	5 °C - 40 °C	20 °C	
ECONO TEMP *)	5 °C - 40 °C	10 °C	
REDUCED TEMP	5 °C - 40 °C	15 °C	
T-LIMIT DAY	----, (-5) °C - 40 °C	19 °C	
T-LIMIT N	----, (-5) °C - 40 °C	10 °C	
HEAT SLOPE	0,00 - 3,00	0,8	
ADAPTION	00, 01 (OFF / ON)	00 = OFF	
ROOMS-INFL	00 - 20	10	
ADAP ROOM-T	(-5,0)K - (5,0)K	0,0K	
OPTIMIZAT	00, 01, 02	00	
M-OPT-TIME	0:00 - 3:00 (h)	2:00 (h)	
ECONO OPTI	0:00 - 3:00 (h)	0:00 (h)	
PC-ENABLE	0000 - 9999	0000	
RETURN	Exit level using 		

HEAT CIRCUIT 1	
Designation	Value range
HEAT PROGRAM 1 => FACTORY SETTING:	Mo. / Tu. / We. / TH. / Fr. : 06:00 to 22:00
	Sa. /Su. : 07:00 to 23:00
HEAT PROGRAM 2 => FACTORY SETTING:	Mo. / Tu. / We. / TH. / Fr. : 06:00 to 08:00, 16:00 to 22:00
	Sa. /Su. : 07:00 to 23:00

HEAT CIRCUIT 2	
Designation	Value range
HEAT PROGRAM 1 => FACTORY SETTING:	Mo. / Tu. / We. / TH. / Fr. : 06:00 to 22:00
	Sa. /Su. : 07:00 to 23:00
HEAT PROGRAM 2 => FACTORY SETTING:	Mo. / Tu. / We. / TH. / Fr. : 06:00 to 08:00, 16:00 to 22:00
	Sa. /Su. : 07:00 to 23:00

HOT WATER	
Designation	Value range
=> FACTORY SETTING:	Mo. / Tu. / We. / TH. / Fr. : 05:00 to 21:00
	Sa. /Su. : 06:00 to 22:00

CIRCULATION	
Designation	Value range
=> FACTORY SETTING:	Mo. / Tu. / We. / TH. / Fr. : 05:00 to 21:00
	Sa. /Su. : 06:00 to 22:00

3.7 - ELECTRICAL AND HYDRAULIC CONNECTIONS OF C.H.

In the fig. 34 the typical connection of the boiler to C.H. system with two heating zones, of which one is with motorized mixing valve. Both, the heating zones are controlled by an outer compensator.

The electrical connections of the heating pumps and the mixing valve motor must be connected strictly according to the schema shown in fig. 32.

The temperature sensors will be connected according to the schema shown in fig. 33.

Remember that all the TRIOPREX-N boilers are for forced circulation.

It is suggested to adopt a shunt pump "Pr" to guarantee the circulation through the boiler in any possible open condition of the mixing valve (see fig. 34).

The shunt pump "Pr", which will have a throughput equal, at least, at 50% of the C.H. pump and a manometric of 1 m W.G., will perform also an anticondensation function, limiting the too cold returns into the boiler.

The hydraulic schemas shown in the figs. 34 & 35 are principle schemas; in case of different system circuits, contact, please, our after sale service dept., which will supply you with all the necessary informations.

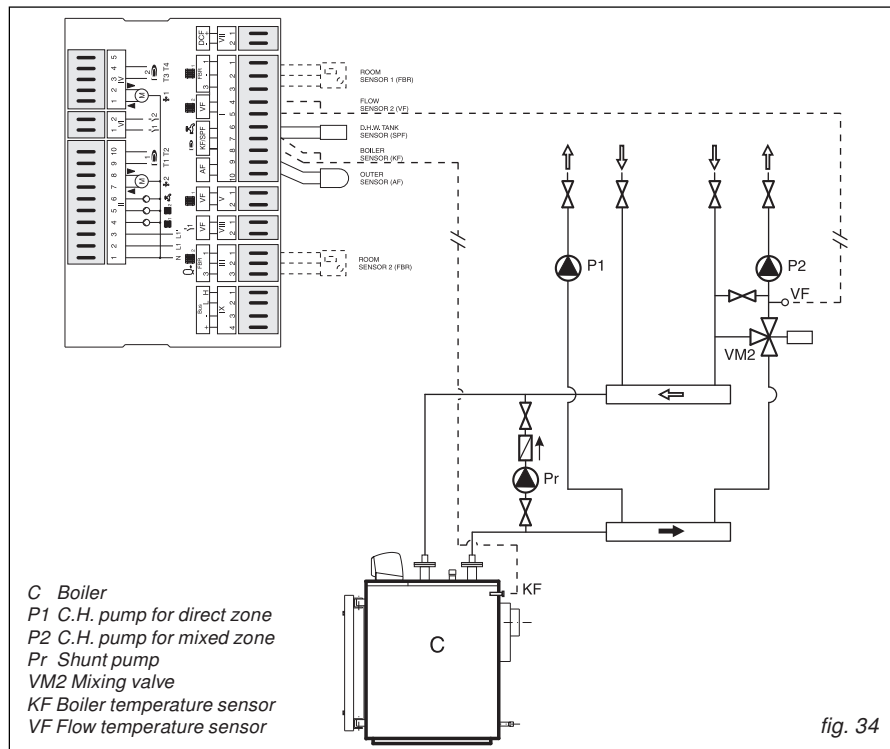

3.8 - ELECTRICAL AND HYDRAULIC CONNECTIONS OF C.H. AND D.H.W. PRODUCTION CIRCUITS

In a C.H. installation equipped with a D.H.W. storage tank, the hydraulic schema, shown in fig. 35, can be used.

Note: Also in this case the remarks made in the previous paragraph are applicable, i.e.: the adoption of a shunt pump (Pr).

The electrical connections of the storage tank loading pump will follow the schema shown in fig. 32.

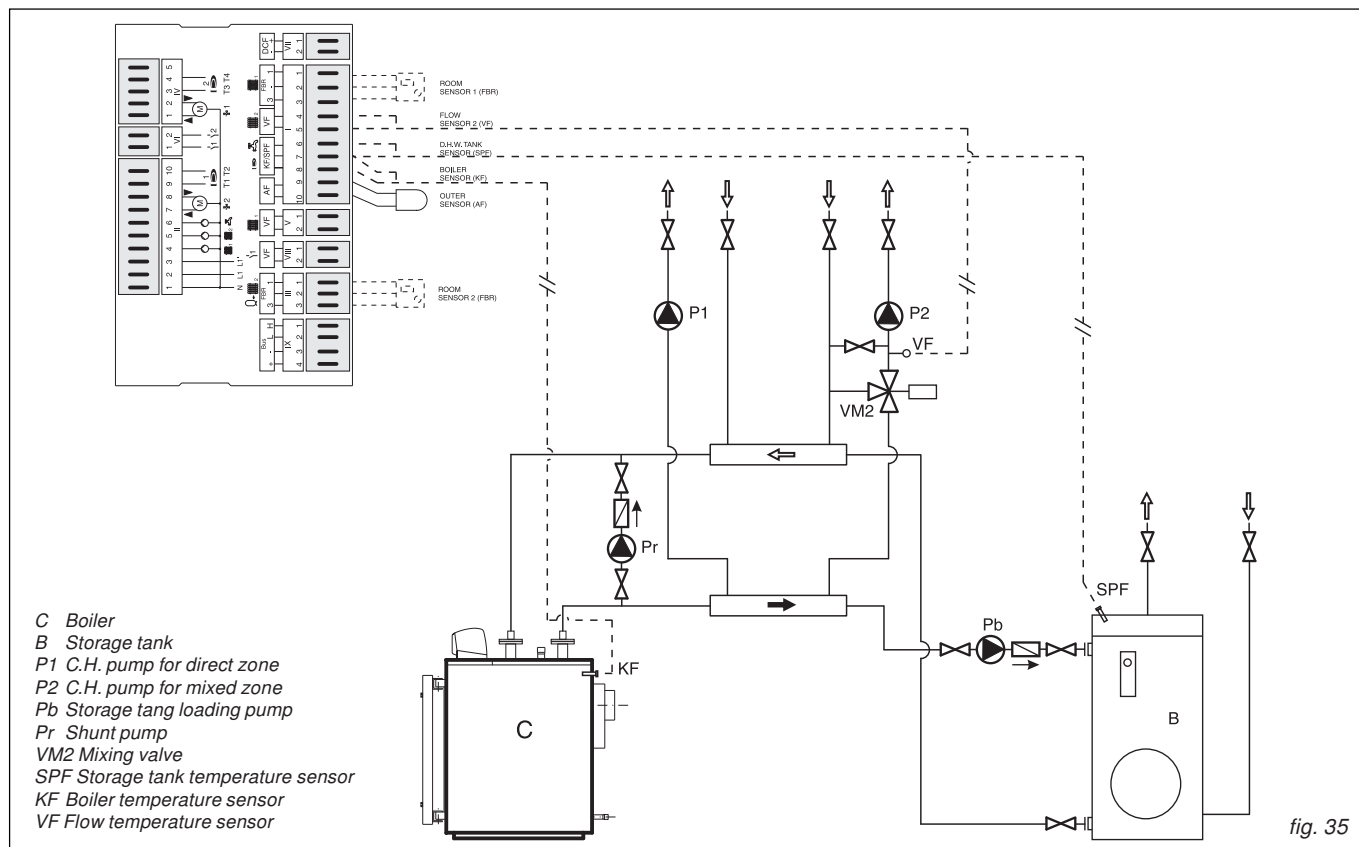

4

COMMISSIONING AND OPERATION

4.1 - POSITIONING OF THE TURBULATORS

The TRIOPREX-N boilers are designed to be used in an output range to improve the seasonal efficiency and the possibility to be adopted in all the heating installations. The output must be adjusted at the commissioning stage, according to the system designer indications and, in any case, within the operation range for each boiler model shown on pages 6 to 10 , by the burner technician, which will determine the fuel throughput.

In any case **the turbulators will be placed, inside the relevant smoke pipes, at a distance, from the front tube plate, as shown in fig. 36.**

When using the boiler at minimum output the smoke temperature will not be lower than 160 °C.

In contrary case, before get in touch with our After Sale Service Dept, ascertain that the turbulators are in all the smoke pipes.

The commissioning of the burner must be performed under the responsibility of a specialized and well trained burner technician, authorised by the burner manufacturer.

In that occasion a commissioning report has to be filled out.

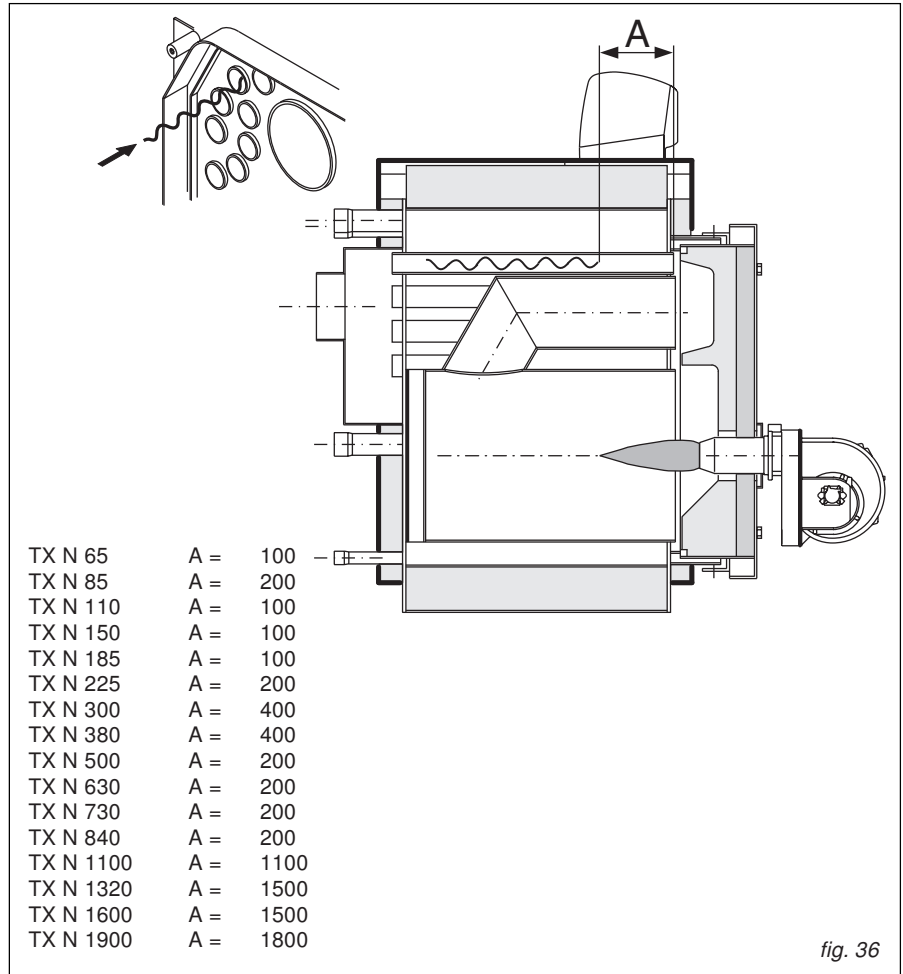
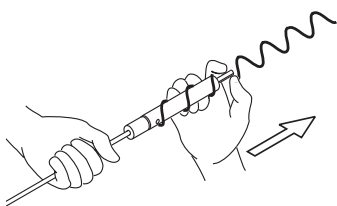

fig. 36

Turbulators removal

Detail 1:
Fit the brush handle extension onto the turbulator remover
Withdraw the pin from turbulator.



Detail 4:
Turn up to unblock the turbulator.

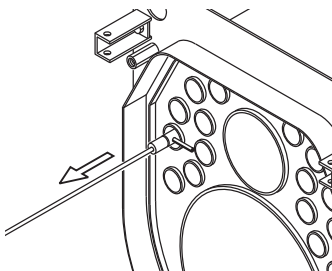

Detail 2:
Fit the pin in the radial hole with a hammer.

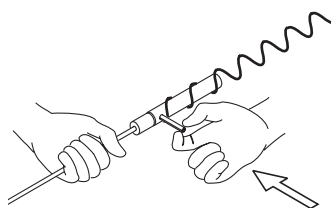

Detail 5:
Withdraw the turbulator

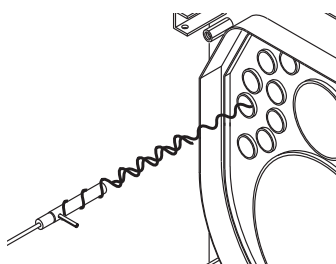

Detail 3:
Screw the turbulator remover onto the turbulator.

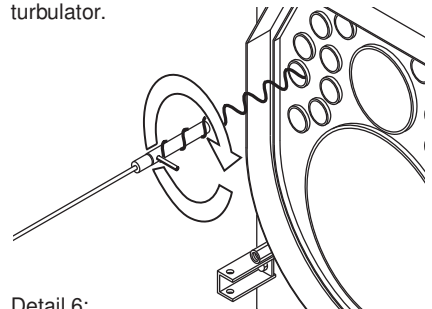

Detail 6:
Turn the remover counterclockwise to release the turbulator

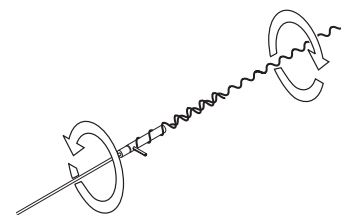

The procedure from detail 3 to 6 has to be repeated for all the turbulators.

fig. 37

4.2 - PRELIMINARY CHECK

Once all the hydraulic, electrical and fuel connections have been made, before starting the boiler we suggest to ascertain that:

- The expansion vessel and the pressure relief valve are correctly connected and are in no way interceptable.
- The bulb of thermometer, working, high limit and minimum thermostats are well secured into their proper bulb holder.
- The turbulators are correctly fitted in all the smoke pipes.
- The C.H. circuit has been washed and rinsed and is free from solid impurities.
- The C.H. circuit is filled with water and has

been completely purged.

- The pumps operate properly.
- The flow switch, the pressure relief valve, and the overheating discharge valve, if any, are adjusted at the right value.
- The fuel, hydraulic, electrical and safety connections are executed in conformity with national and local requirements in force.
- There are no water leaks.
- The burner has been fitted according to the instructions of the burner manufacturer.
- The mains voltage and frequency are compatible with the burner and the electrical

equipment of the boiler.

- The burner is adjusted for the fuel type, among those listed in the burner data plate, available on the installation site, and the burner output range is compatible with the boiler output.
- In the boiler house there are also the burner instructions.
- The C.H. pipes are properly insulated.
- The C.H. system is capable to absorb the heating quantity produced at the first start of the burner, during the test period.
- **The shunt pump is installed as prescribed in the paragraph 2.5.6.**

4.3 - FIRST COMMISSIONING

At the commissioning stage of the boiler a qualified technician has to perform the following checks:

- Internal and external sound test of burner and fuel feeding pipe;
- Adjustment of the fuel throughput according to the nominal input of the boiler (it is convenient to remember that the nominal input can be adjusted between the minimum and the maximum shown in the table of pages 6 to 10), by sharing the output between the 1st and the 2nd stage, knowing that the 1st stage flame can go down to the 60% of the nominal output (which at its turn can vary between the minimum and the maximum depending on the output requested by the C.H. system).

Proceed, then, in the following way:

- Open the fuel feeding cock and check that there are no leaks in the feeding line.
- Ascertain that all the switches of the panel board are in OFF position and adjust

the working thermostat to the minimum position.

- Switch ON the panel board through the main switch.
- Switch ON the C.H. pump: it will start to rotate as soon as the minimum water temperature thermostat detects 50 °C.
- Switch the burner ON.
- Position the working thermostats of 1st and 2nd stages to the maximum setting to create a heat request.

During this phase check that:

- There are no smoke leaks from the front door, the burner plate and the chimney connection.
- There is a draught at the chimney base between 2 and 4 mm w.g.
- There are no water leaks.
- The different thermostats and the other installation safety devices work properly.
- The shunt pump operates correctly.
- The burner ignition is good.

- The burner characteristics (main adjustments and nozzle type) correspond to the boiler data plate.

With a burner properly adjusted it must be possible to reach easily, from a smoke sample taken at the chimney base, the values given below:

- 1) With light oil having a maximum viscosity of 1.5 °E at 20 °C:
 - CO₂ = 12 to 13 %
 - Smoke index < 1
 - Smoke temperature = 180 to 200 °C
- 2) With Natural Gas:
 - CO₂ = 9 to 10 %
 - Smoke temperature = 160 to 180 °C (values related to a clean boiler, with water at 70 °C).

It is suggested to adjust the fuel throughput to the actual needs of the C.H. installation (avoid to overcharge the boiler), without exceeding the a.m. smoke temperatures (never go below 160 °C).

4.4 - OPERATION OF THE BOILER

The HIGH EFFICIENCY TRIOPREX-N boilers are foreseen to operate with a return water temperature never below 54 °C when operated on light oil, and never below 59 °C when operated on gas, to avoid (or, at least, to reduce) the smoke acid condensation phenomenon, which can be the reason of a premature deterioration of the steel boiler body. The working thermostat, pos. 32 of the panel board, must be set at a temperature of approximately 80 to 85 °C.

The room temperature will be compulsorily adjusted through a mixing valve and, eventually, an outer compensator.

To homogenise the water temperature, or avoid as maximum as possible, returns into the boiler at a temperature below 54 °C when operated on oil, or 59 °C when operated on gas, a properly dimensioned shunt pump must be fitted between flow and return pipes of the boiler.

N.B. The metal sheet corrosion due to the acid

condensate is not covered by the guarantee because it depends only from the operation of the C.H. system.

The TRIOPREX-N panel board is equipped with a low temperature thermostat not allowing the operation of the pump when the boiler temperature is below 50 °C (protection against cold starts).

4.5 - SWITCH OFF OF THE BOILER

- Switch OFF the burner (switch No.12 to 0 position).

- Leave the pumps working up to when they are not stopped by the minimum thermostat.
- Switch OFF the power to the boiler panel

board.

- If it is decided not to use the boiler for a long period close also the gate valves of the fuel.

5

MAINTENANCE

5.1 - GENERAL RULES

Before effecting any operation of cleaning or maintenance, disconnect the boiler from the electrical supply acting on the main switch onto the panel board.

In case of failure or bad operation of the boiler, switch it off, abstaining your self from any attempt of repair or direct intervention.

Exclusively address to professionally qualified personnel.

The possible reparation of the boiler must be effected by an authorized service center using only original spare parts.

The non respect of the above can jeopardize the safety of the boiler.

To guarantee the efficiency of the boiler and for its correct operation it is essential to submit the boiler to an annual maintenance, through a professionally qualified technician, according to the indications of the manufacturer.

When it is decided not to use the boiler anymore, the parts which can be potential sources of danger shall be made harmless. After a month of boiler operation, open the front door and ascertain the smoke pipes are clean.

In case of a heavy dirtiness:

- Remove the turbulators from smoke pipes.
- Clean all the smoke pipes using the brush delivered with the boiler.
- Open the two cleaning doors on the sides of the smoke chamber and remove, with a vacuum cleaner all the soot.
- Relocate the two cleaning doors and the turbulators; then close the boiler front door and check for soundness all around the sealing rope.
- Then adjust the burner.

Note: With a burner properly adjusted only a cleanup at the season end is necessary.

5.2 - ORDINARY MAINTENANCE

The boiler operating condition are very different from one case to the other and depend on the fuel used, on the adjustment of the burner, on the number of starting, on the C.H. system characteristics, etc. and for that reason it is not possible to establish, in advance, the frequency of the maintenances.

It is, then, necessary that the technician, who performs the first cleaning, establish the cleaning frequency on the base of the boiler status.

Generally, we suggest the following frequency, according to the fuel used:

- Gas fired boilers: once a year.
- Oil fired boilers: twice a year or more often if there is reason to doubt of their adjustment.

In any case the local rules in force have to be complied with.

We suggest to shake the turbulators, without removing them from the smoke tubes, at least once a month of operation, not to allow the soot blocking them and making them extremely difficult to be removed.

During the operations of ordinary maintenance it will be necessary to brush the tube bundle

- after the removal of the turbulators - and the furnace and collect the soots through the cleaning doors on the smoke chamber.

Besides it will be necessary to verify the good operation of the protection and control devices (thermostats, thermometers) of the boiler and of the plant (manometers, flow and pressure switches, expansion vessels) and all the safety devices.

In this occasion it will be necessary to notice the quantity of reinstatement water used and decide, also in base to its hardness, an intervention of preventive descaling.

It must be considered that the calcium and magnesium salts dissolved in the raw water, with repeated reinstatements, can cause deposits in the boiler that hinder the inner circulation and subsequent overheating of the wall plates with possible serious damages that cannot be attributed to the constructive geometry and/or to the materials used and to the constructive technique and, therefore, they are not covered by guarantee.

On the occasion of the ordinary maintenance it is useful to perform a small discharge from the boiler to verify if sludges escape.

In affirmative case, it will be necessary to

prolong the discharge up to get clear water. At the end of the drainage it will be necessary to reestablish the level of the water in the system.

At the end of the smoke circuit cleaning, to the next restart check around the burner plate and the smoke chamber for smoke leaks. In the case some smoke leaks were noticed, first of all tighten the nuts fitting the smoke chamber and, not getting result, it will be necessary to replace the sealing gasket.

Similarly it will be necessary to act on the front door, increasing at first the tightening of the nuts (after having loosened the inner counternuts) and then, if necessary, by replacing the whole gasket.

If it was necessary to center the sealing gaskets on the sealing ring of the door it is possible to adjust the door position by acting as suggested on the paragraph 2.6.

At the end check and, if necessary, restore the sealing of the connection of the chimney and of the burner with the door.

The performed operations must be recorded on the log book of C.H. system.

5.3 - EXTRAORDINARY MAINTENANCE

Extraordinary maintenance of end season or for long periods of inactivity.

It will be necessary to perform all the operations described in the preceding chapter and besides:

- Check the state of consumption of the turbulators to replace them in time.
- To facilitate the extraction of the turbulators, with the TRIOPREX-N boilers a special extractor is supplied.
- After the cleaning of the smoke circuit it is convenient to pass in the smoke pipes and in the furnace with a rag soaked of

diluted solution of caustic soda.

After having let to dry cross again all the surfaces with a rag soaked of oil.

Perfectly close the the burner air intake to avoid a continuous passage of damp air through the boiler recalled by the chimney it self.

It is advisable to put inside the furnace some alive mortar that has an hygroscopic action.

- Do not empty the C.H. system and the boiler.
- Protect the screws with graphitized fat, nuts and pivots of the door.
- Show all the operations that must be perform to the following put into operation

particularly the operation of the shunt pump must be checked.

5.4 - CLEANING OF THE BOILER

Follow the next sequence:

- Close the feeding of the oil.
- Cooldown the boiler to the ambient temperature.
- Switch Off the electrical supply to the boiler and the burner.

- Open the front door.
- Shake and remove the turbulators every 15-20 days of activity of the boiler to avoid that the residues of combustion can stop them so much to make difficult their removal.
- Clean the turbulators and the smoke pipes by brushing them with the brush supplied.
- Reposition the turbulators.
- Remove the cleaning door and all the soot

- from the smoke chamber.
- Re-fit the cleaning doors.
- Verify the state of the refractory insulation of the combustion chamber door.
- Verify the state of the door sealing rope.
- Close the door of the furnace.

5.5 - CHECK OF THE BOILER OPERATION

For a safe operation of the boiler it is necessary to check:

- The good operation of the working thermostat.

- The good operation of the high limit thermostat.
- The adjustment and the good operation of the minimum thermostat.
- The good operation of the shunt system.
- The good operation of the outer compensator (if fitted).

- The good operation of all the other safety and control devices imposed by local requirements.

5.6 - CHECK OF THE BURNER OPERATION

- See the burner instruction manual.
- Follow all the local requirement in terms of burner maintenance .

5.7 - BOILER HOUSE

For the combustion of oil or gas the burner needs air.

Accordingly wide openings are foreseen for the entry of the air in the boiler house.

These openings never have to be obstructed. Maintain the boiler house clean and dust free. The boiler house is not a closet: avoid to store any kind of materials. Maintain the entry of the boiler house free and easy to reach in any moment.

Ascertain that the boiler house is endowed with efficient emergency lamp.

Note:

Note:

Unical AG S.P.A.

46033 Casteldario - Mantova - ITALIA - tel. ++39.0376.57001 (r.a.) - telefax ++39.0376.660556
www.unical.ag info@unical-ag.com

Unical AG declines any liability for the inaccuracies that may appear due to errors in transcription or printing. It also reserves the right to introduce those modifications to its products that it considers necessary or useful, without compromising the essential characteristics of the said products.